

## ΕΠΙΤΡΑΠΕΖΙΑ ΒΙΤΡΙΝΑ ΣΑΛΑΤΩΝ SA PI 209T

### PRODUCT SPECIFICATIONS

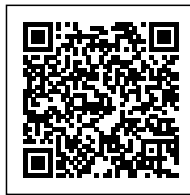

<b>Weight</b>	53 kg
<b>Dimensions</b>	209 × 34 × 45 cm
<b>Δίσκοι GN</b>	10 (1/4)
<b>Ιπποδύναμη (HP)</b>	1/6
<b>Όγκος (m3)</b>	0.30



---

**SKU:** SA PI 209T

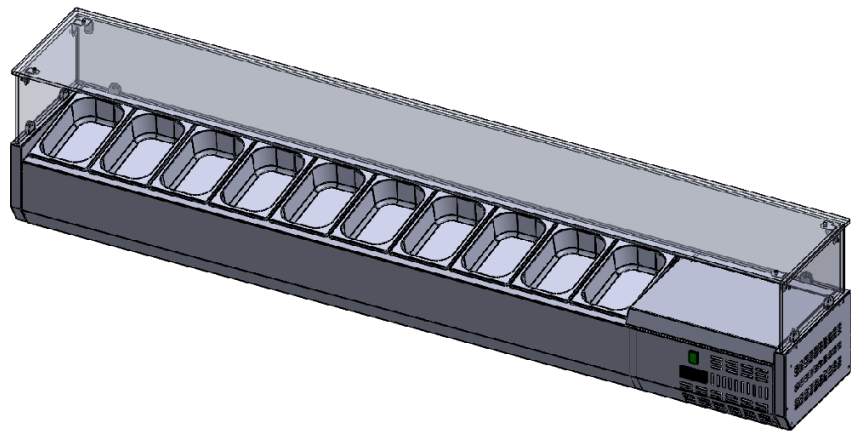
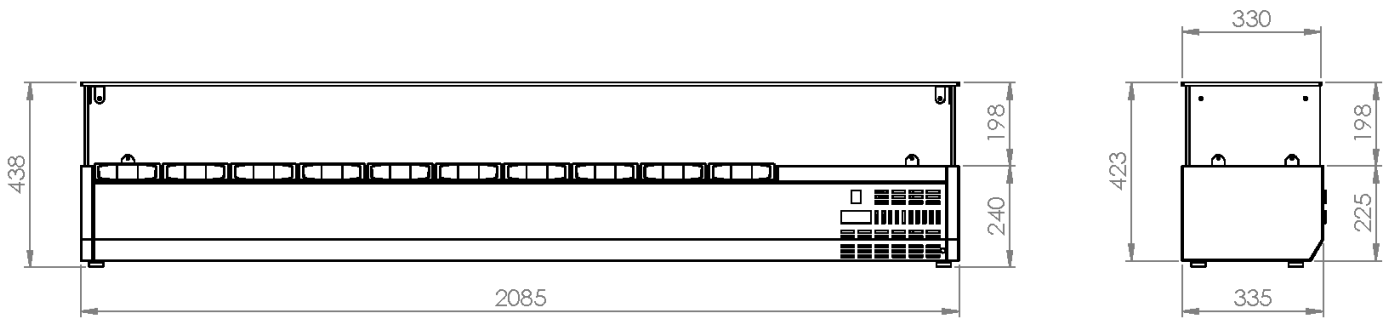

<b>Refrigerated countertop salad display</b>		<b>SA PI 209T</b>

Capacity:	10 GN Trays (1/4)
-----------	-------------------