



# EKTOR 37

## estrattore slow Juicer



Estrattore a bassa velocità per l'estrazione di succhi a freddo da frutta e verdura.

- Struttura esterna in acciaio inox
- Speciale tramoggia di introduzione che agevola il carico dei pezzi più grossi
- Coclea ad alta efficienza
- Tappo salvagoccia
- Pratico e veloce smontaggio delle parti interessate alla lavorazione
- Pestello per agevolare l'avanzamento dell'alimento inserito
- Spazzola per la pulizia
- Vaschetta per gli scarti e una per il succo
- Dotato di 3 cestelli con diversa foratura, anche per sorbetti
- Potente motore asincrono ventilato con riduzione ad ingranaggi

### Opzioni:

- Filtro vaschetta succo

*Low-speed juicer extractor for fruits and vegetables.*

- *Stainless steel construction*
- *Special introduction hopper for easy loading of larger pieces*
- *High efficiency screw propeller*
- *Drip cap*
- *Quick and easy disassembly of the parts used for processing*
- *Pestle for easy introduction of the products.*
- *Cleaning brush*
- *Equipped with 2 trays: one for juice and one for waste*
- *Equipped with 3 different drilling strainers*
- *High efficiency asynchronous ventilated motor*

### Optionals:

- *Filter*



Tappo salvagoccia.  
Drip cap



Vaschetta per gli scarti  
Tray for waste



Speciale tramoggia di introduzione che agevola il carico dei pezzi più grossi  
*Special introduction hopper for easy loading of larger pieces*





BPA Free



Filtro opzionale  
Optional filter

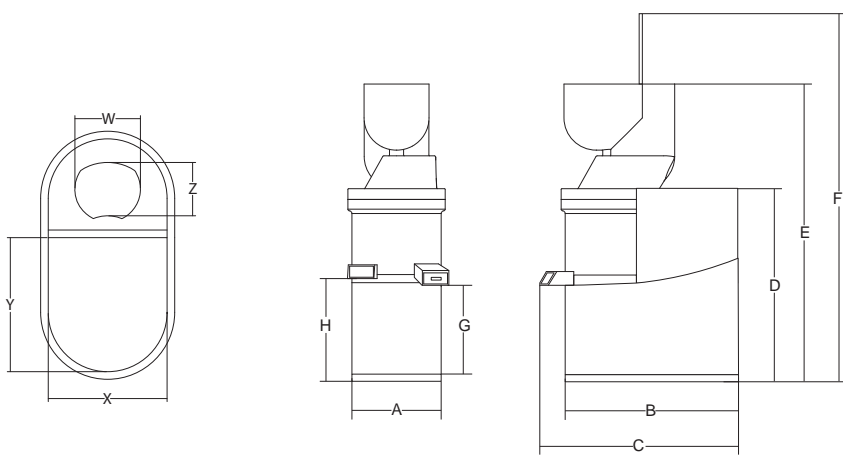

	watt	r.p.m.	mm	mm	mm	mm	mm	mm	mm	mm	mm	mm	kg	mm	kg
Ektor 37	400	1ph	37	X=78 / Y=88 W=43 / Z=35	150	228	240	290	450	530	157	163	6.7	370x290x340	8

