

INSTRUCTION MANUAL, FOR USE AND MAINTENANCE

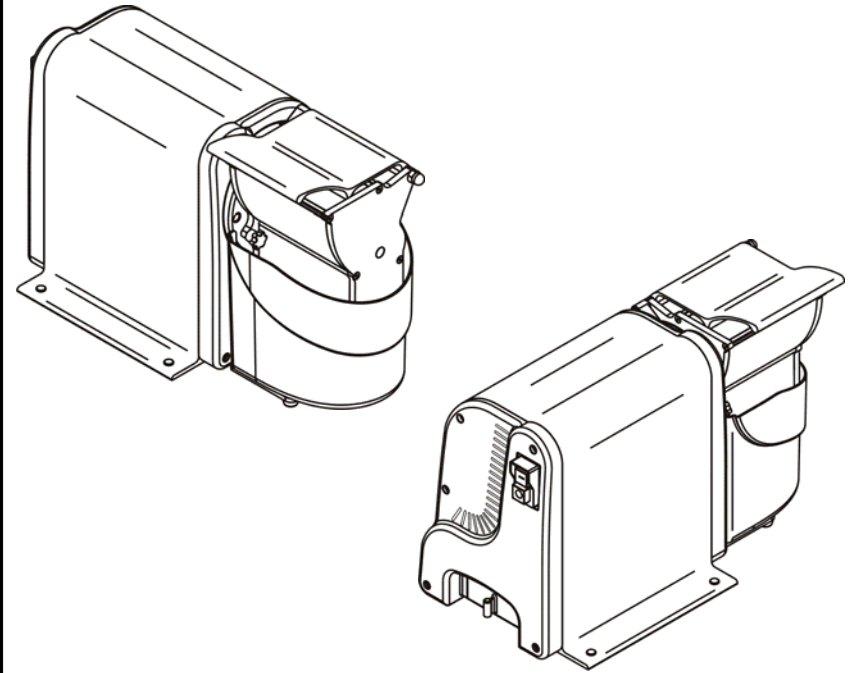

Ed. 05/2011

**SERVICE CENTRE
AUTHORIZED DEALER**

**CE Graters
VGS - DVR**

8.2 - WEEE Waste Electrical and Electronic Equipment



Pursuant to Art. 13 of Legislative Decree No. 151 dated 25 July 2001, "Implementation of Directives 2002/95/EC, 2002/96/EC and 2003/108/EC, regarding the reduction of the use of hazardous substances in electrical and electronic equipment as well as waste disposal"

The barred garbage bin symbol on the device and its packaging indicate that at the end of its useful life the product must be collected separately from other waste.

Separate collection of this equipment once it has reached the end of its life is organized and managed by the manufacturer. The user who wishes to dispose of this equipment must thus contact the manufacturer and follow the system that it has adopted to allow for separate collection of the equipment once it has reached the end of its life.

Separate collection for recycling of the equipment, its treatment and environmentally compatible disposal prevents any possible negative effects on health and the environment and promotes the reuse and/or recycling of the materials used to make the equipment.

Illegal waste disposal on the part of the user will result in administrative sanctions provided for in the current regulations.

CHAP. 6 - ORDINARY CLEANING

6.1 - GENERAL INFORMATION

- Cleaning the machine should be performed at least once a day or, if necessary, more frequently.
- Cleaning must be carefully performed on all parts of the grater that come in direct or indirect contact with food.
- The grater must not be cleaned with pressure washers, jets of water or dishwashers; utensils, brushes and anything else that might damage the surface of the machine must not be used.
- Before any type of cleaning, always **disconnect the power plug in order to completely isolate the machine from the rest of the electrical system.**

ATTENTION! to residual risks from sharp and/or pointed parts.

ATTENTION!

DO NOT PUT ANY COMPONENTS IN THE DISHWASHER.

6.2 - PROCEDURE

Cleaning the body of the machine at the workplace can be done with a damp cloth that is frequently rinsed in water.

ATTENTION: Clean the grater roller with a brush, paying close attention to the teeth.

CHAP. 7 - MAINTENANCE

7.1 - GENERAL INFORMATION

Before any type of maintenance, always **disconnect the power plug in order to completely isolate the machine from the rest of the electrical system.**

7.2 - FEET

The feet, over time, could deteriorate and lose their elasticity, reducing the machine's stability. They then must be replaced.

7.3 - POWER CABLE

Periodically check the condition of the cable and, if necessary, call the "HELP CENTRE" for a replacement.

CHAP. 8 - DISPOSAL

8.1 - DECOMMISSIONING

If for any reason you decide to decommission the machine, be sure that it cannot be used by anyone: disconnect the electrical connections.

INTRODUCTION

- *This manual was developed to provide the **customer** with all information about the machine and the regulations applied to it, as well as use and maintenance instructions which allow it to be used in the best manner and maintain its efficiency over time.*
- *This manual is to be delivered to those who will use the machine and perform periodic maintenance.*

INDEX

CHAP. 1 - INFORMATION ON THE MACHINE	page 5
1.1 - GENERAL PRECAUTIONS	
1.2 - SAFETY DEVICES INSTALLED ON THE MACHINE	
1.3 - DESCRIPTION OF THE MACHINE	
1.3.1 - General description	
1.3.2 - Construction characteristics	
1.3.3 - Machine composition	
CHAP. 2 - TECHNICAL DATA	page 8
2.1 - DIMENSIONS, WEIGHT, CHARACTERISTICS...	
CHAP. 3 - RECEIPT OF THE MACHINE	page 9
3.1 - SHIPPING THE MACHINE	
3.2 - CHECKING THE PACKAGE UPON RECEIPT	
3.3 - PACKAGING DISPOSAL	
CHAP. 4 - INSTALLATION	page 10
4.1 - LOCATION OF THE MACHINE	
4.2 - ELECTRICAL CONNECTION	
4.2.1 - Grater with monophase motor	
4.3 - ELECTRICAL DIAGRAMS	
4.3.1 - Monophase electrical diagram	
4.4 - OPERATIONAL INSPECTION	
CHAP. 5 - USING THE MACHINE	page 12
5.1 - CONTROLS	
5.2 - LOADING THE PRODUCT	
CHAP. 6 - ORDINARY CLEANING	page 14
6.1 - GENERAL INFORMATION	
6.2 - PROCEDURE FOR CLEANING THE MACHINE	
CHAP. 7 - MAINTENANCE	page 14
7.1 - GENERAL INFORMATION	
7.2 - FEET	
7.3 - POWER CABLE	

CHAP. 8 - DISPOSAL

8.1 - DECOMMISSIONING

8.2 - WEEE Waste Electrical and Electronic Equipment

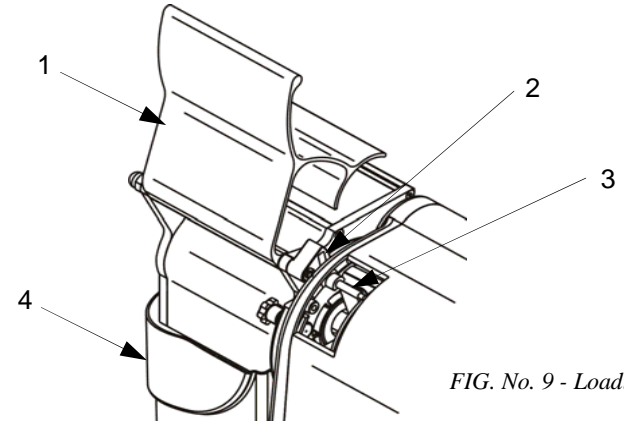

FIG. No. 9 - Loading the product

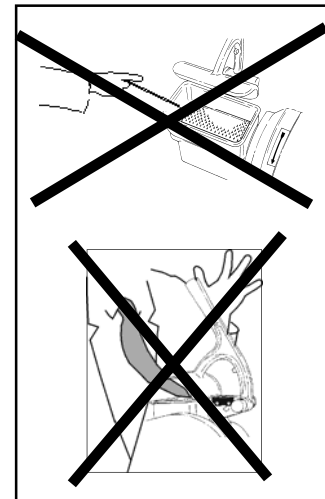

FIG. No. 10 - Pay close attention to...

Do not insert metal or other objects inside the grater hopper and the outlet for grated material.
Do not wear clothing that could snag during use.



FIG. No. 11 - Correct position

CHAP. 5 - USING THE MACHINE

5.1 - CONTROLS

The controls are located on the body of the machine as shown in FIG. No. 8.

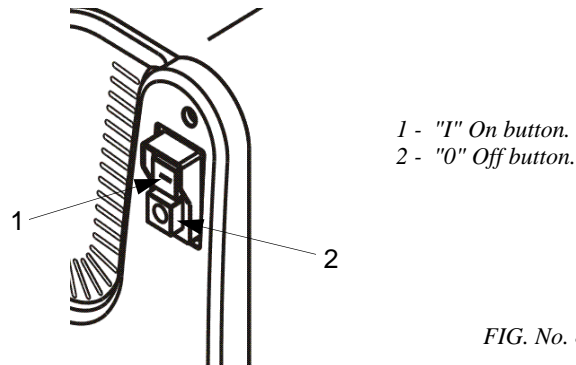

FIG. No. 8 - Control locations

5.2 - LOADING THE PRODUCT (see FIG. No. 9-10)

Please Note: The food to be processed is only loaded when the motor is off.

The procedure is as follows:

1. **ATTENTION!** Never, for any reason, put your hands in the hopper grater when it is running, shut the machine off and carefully make sure to avoid any contact with the grater roller.
2. The food to be processed is always loaded with the motor off;
3. Lift the grater lever (1) and place the product in the grater hopper, blocking it with the grater lever. The amount of product loaded in the hopper must allow for the lever to be closed.
4. Ensure that the collection bowl (4) is correctly in place (or inserted completely until it touches the body of the machine) so that the micro (3) connects and allows the machine to be turned on.

Please Note: If the lever is not closed and the collection bowl is not in place, the machine will not function.

5. Turn the machine on using the "I" button (ref. 1 - FIG. No. 8);
6. When finished, turn the machine off by pushing the "0" off button (ref. 2 - FIG. No. 8), then dismantle and carefully clean the hopper and all components (see Par. 6.2).

Whenever the bowl is removed and repositioned, you must restart the machine by pressing the "I" on button.

Please Note: Avoid running the machine while empty.

CHAP. 1 - INFORMATION ON THE MACHINE

1.1 - GENERAL PRECAUTIONS

- The machine must only be used by trained personnel who must be perfectly knowledgeable of the safety regulations contained in this manual.
- In the event of personnel turnover, provide for training time.
- Even though safety devices are installed on the machine's danger zones, avoid getting hands close to moving parts or touching the machine with wet or damp hands.
- Before performing any cleaning or maintenance, disconnect the machine's power plug from the electrical supply.
- When conducting maintenance or cleaning of the machine (and the safety devices are removed), carefully evaluate the residual risks.
- During maintenance or cleaning, maintain concentration on the operation underway.
- Regularly inspect the condition of the power cable (in order to avoid danger, be sure to uncoil the entire length of the power cable, preventing any twisting); avoid putting pressure on the cable with any kind of weight, leaving it in contact with hot or sharp surfaces and pulling on it to unplug it from power.
- If you suspect a malfunction or the machine demonstrates one, do not use it or make repairs; contact the "Help Centre" on the back of this manual.
- Do not use the machine for frozen goods or for non-alimentary products.
- Do not put metal or other objects inside the grater hopper.
- **Never grate food without using the press lever.**

The manufacturer is absolved of all responsibility in the following cases:

- ⇒ tampering with the machine or installed safety devices by unauthorised personnel;
- ⇒ replacement of parts with non original ones;
- ⇒ failure to carefully follow the instructions in this manual;
- ⇒ treatment of the surfaces of the machine with inappropriate products (inflammable, corrosive or harmful substances).

1.2 - SAFETY DEVICES INSTALLED ON THE MACHINE

Safety devices that protect against electrical hazards have been made in compliance with Directive **2006/95/EEC** and **2006/108/EEC**, while mechanical safety devices were made in compliance with Directive **2006/42/EEC**.

The grater is thus provided with:

- a relay in the control circuit that requires a voluntary restart of the machine in the event of accidental power outage.
- micro-magnet (1) which stops the machine when the grater lever is lifted;
- micro-magnet (2) which stops the machine when the bowl is removed and allows it to be restarted only if contact is restored between the magnet and micro.

The grater is equipped with regulatory measures for electrical and mechanical protection during operation as well as during cleaning and maintenance.

There are, however, **RESIDUAL RISKS** that cannot be completely eliminated, which are highlighted in this manual under the title, **ATTENTION!**

These refer to cutting danger from handling the roller while cleaning the machine.

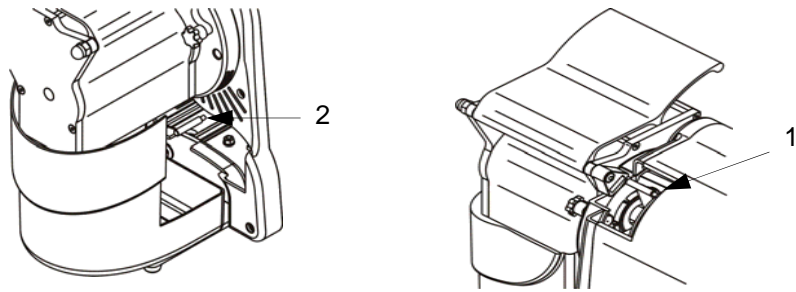

FIG. n°1 - Posizione delle sicurezze

1.3 - DESCRIPTION OF THE MACHINE

1.3.1 - General description

The grater was designed and manufactured by our company with the precise goal of ensuring:

- maximum safety during use, cleaning and maintenance;
- maximum hygiene, obtained due to meticulous selection of the materials that come in contact with the food and by the elimination of rough edges in the part of the machine that comes in contact with food in order to obtain easy and complete cleaning as well as to facilitate dismantling;
- sturdiness and stability of all components;
- great manageability.

1.3.2 - Construction characteristics

The grater was manufactured using the following materials:

- body of the machine in extruded aluminium;
- side coverings in ABS;
- grater roller in stainless steel;
- collection bowl in thermoformed alimentary plastic.

These guarantee contact with the food (cleanliness) and its invulnerability to acids and salts as well as a high resistance to oxidation.

4.3 - ELECTRICAL DIAGRAMS

4.3.1 - Monophase electrical diagram

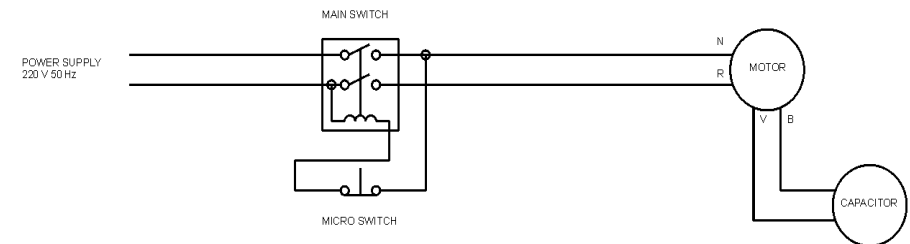

FIG. no. 6 - Mn electrical diagram

4.4 - OPERATIONAL INSPECTION

To check that the machine is functioning correctly, follow the following procedure:

- press the "I" on button and the "O" off button, making sure the grater roller turns counter-clockwise. Looking at this from above the hopper (*see FIG. no. 7*) you should see the roller teeth move from left to right.
- check that the machine starts when the press lever is lowered and stops when it is lifted.

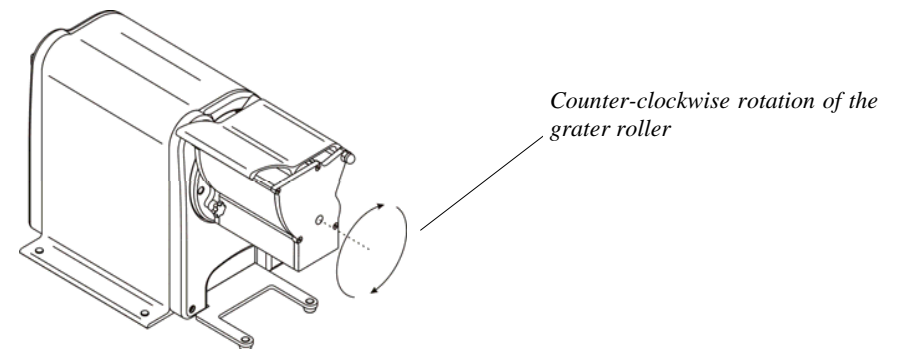

FIG. no. 7 - Rotation of the grater roller

3.2 - CHECKING THE PACKAGE UPON RECEIPT

Upon receipt of the parcel, if there is no external damage, proceed with opening it, making sure that all of the material is inside (see FIG. No. 4). If, on the other hand, upon delivery of the parcel it shows signs of mistreatment, impact or being dropped, you must bring the damage to the courier's attention and, within 3 days of the date of delivery indicated on the documents, make a precise report of any damage to the machine. Do not overturn the package!! When transporting, make sure it is firmly held at the 4 fundamental points (keeping it parallel to the ground).

3.3 - PACKAGING DISPOSAL

The package components (cardboard, any pallets, plastic straps and polyurethane foam) are solid urban waste and thus can be disposed of without difficulty.

In the event that the machine is installed in countries with special regulations, dispose of the packaging according to the current regulations.

CHAP. 4 - INSTALLATION

4.1 - LOCATION OF THE MACHINE

The location where the machine will be located must take into account the dimensions indicated in Table 1 and thus must be large enough, level, dry, smooth, sturdy, stable and at a height of 80 cm. from the ground. The machine must also be situated in a non-saline environment with a max. humidity of 75% and a temperature between +5°C and +35°C; or in environments that do not lead to its malfunction.

4.2 - ELECTRICAL CONNECTION

4.2.1 - Grater with monophase motor

The grater is supplied with a 3x1mm.² power cord; 1.5m long and a "SHUKO" plug. Connect the machine to 230 Volt 50 Hz, with a magnetothermic 10A circuit breaker, $\Delta I = 0.03A$. Make certain at this point that the grounding device is functioning correctly. Also make sure that the data reported on the technical/serial number label (FIG no. 5) correspond with the data reported on the delivery and lading documents.

Mod.	_____	Watt.	_____
Matr.	_____	A.	_____
	H.p.	_____	Hz.
○	~	Volts.	_____
Anno	_____	Kg.	○

FIG. no. 5 - Technical/serial number label

1.3.3 - Machine composition

FIG. No. 2 - General view of the machine

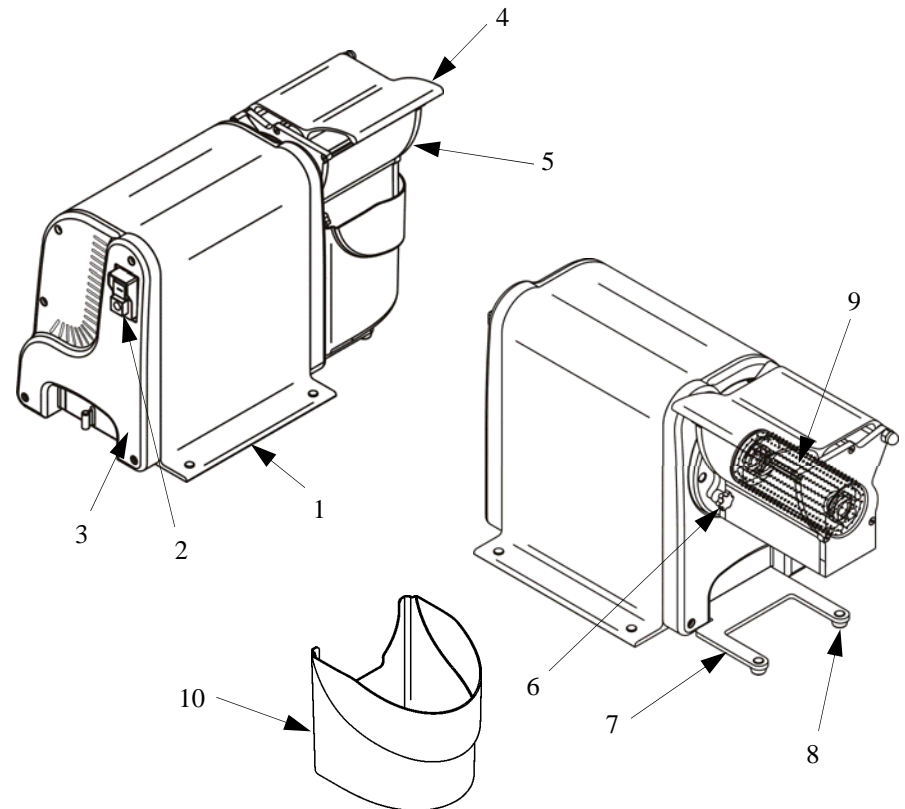

LEGEND:

- 1 - Machine body
- 2 - Controls
- 3 - side covers
- 4 - Pushin lever of the grater
- 5 - Grater opening
- 6 - Knob to fix the openings
- 7 - Anti-tip bracket
- 8 - Feet
- 9 - Grating roller
- 10 - Collecting cup

CHAP. 2 - TECHNICAL DATA

2.1 - DIMENSIONS, WEIGHT, CHARACTERISTICS ...

FIG. no. 3 - Dimension drawings

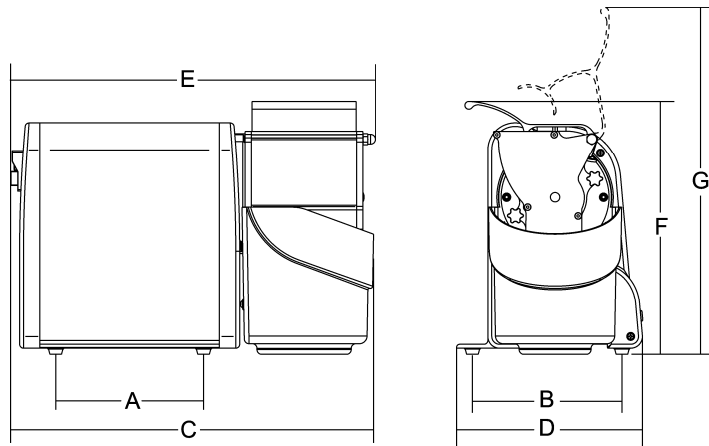

TAB. no. 1 - DIMENSIONS AND TECHNICAL CHARACTERISTICS

Model	u.m.	GF VGS	GF DVR
Power	Watt/Hp	250/0,30	370/0,50
Power source		230V / 50 Hz	230V / 50 Hz
Mouth dimensions	mm	115x65	135x65
Drum revolutions	r.p.m.	1.400	1.400
A x B	mm	180x170	190x190
C x D x F	mm	442x212x302	465x238x325
E x D x G	mm	428x212x420	468x238x444
Net weight	Kg	14	15
Noise level	dB	≤ 60	≤ 60

ATTENTION: The electrical characteristics for the machine are indicated on one of the labels attached to the back of the machine; before connecting it to power, see **4.2 electrical connection**.

CHAP. 3 - RECEIPT OF THE MACHINE

3.1 - SHIPPING THE MACHINE (see FIG. no. 4)

The machine leaves our warehouses carefully packaged, the package includes:

- a) external box in heavy cardboard;
- b) the machine;
- c) this manual;
- d) bowl;
- e) EC certificate of compliance.

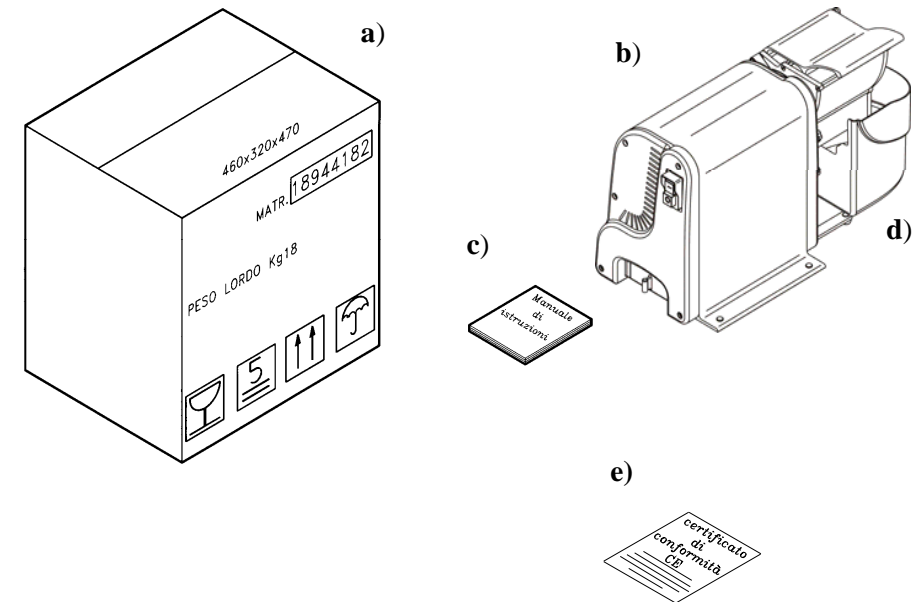

FIG. no. 4 - Package description