

CE Professional Spiral Dough mixers

HRC 20 - 30 - 40 - 50 / VV / 2V
HRC TA 20 - 30 - 40 - 50 / VV / 2V

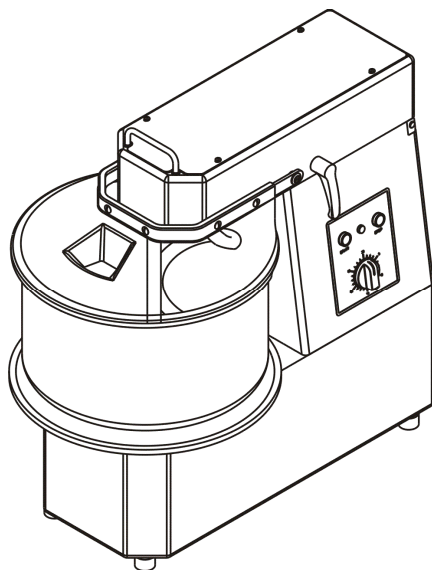
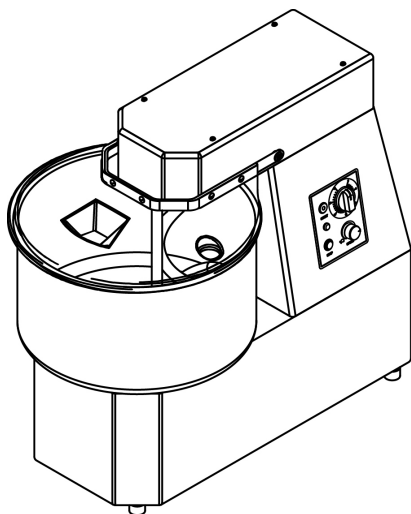

Ed. 007 - 10/2025

English

Use And Maintenance Instruction Manual

INTRODUCTION

- *This manual has been drawn up in order to provide the **customer** with all information on the machine and relevant standards, as well as use and maintenance instructions that allow the appliance to be used at its best, keeping efficiency integral over time.*
- *This manual must be conserved and kept integral until disposal of the machine.*
- *This manual is to be provided to persons using the machine and for its periodic maintenance.*

CHAPTER INDEX

CHAP. 1 - RECEIVING THE MACHINE	page 5
1.1 - PACKAGING	
1.2 - PACKAGING CHECK ON RECEIPT OF THE PACKAGE	
CHAP. 2 - INSTALLATION	page 7
2.1 - UNPACKING	
2.2 - POSITIONING	
2.3 - ELECTRIC CONNECTION	
2.3.1 - Dough mixer with single phase motor 230 V	
2.3.2 - Dough mixer with three phase motor 400 V	
2.3.3 - Tank rotation direction	
2.3.4 - Dough mixer with three phase motor 230 V	
2.4 - PRELIMINARY CHECKS	
CHAP. 3 - INFORMATION REGARDING THE MACHINE	page 10
3.1 - GENERAL PRECAUTIONS	
CHAP. 4 - LEARNING ABOUT THE DOUGH MIXER	page 11
4.1 - CONSTRUCTIVE CHARACTERISTICS	
4.1.1 - Machine set-up with fixed head and bowl	
4.1.2 - Machine set-up with liftable head and removable bowl	
4.2 - SAFETY SYSTEMS INSTALLED ON THE MACHINE	
4.2.1 - Mechanical safety systems	
4.2.2 - Electrical safety systems	
4.3 - DESCRIPTION OF THE MACHINE	
4.4 - MACHINE NOISE LEVEL	
4.5 - OVERALL SIZE, WEIGHT, CHARACTERISTICS.	
CHAP. 5 - USING THE MACHINE	page 17
5.1 - STARTING UP THE MACHINE	
5.2 - MACHINE WITH LIFTABLE HEAD AND REMOVABLE BOWL	
5.3 - PRODUCTIVITY AND DURATION OF THE PRODUCTION CYCLE	
CHAP. 6 - ROUTINE CLEANING	page 19
6.1 - GENERAL	
6.2 - CLEANING THE MACHINE	
6.3 - MACHINE WITH LIFTABLE HEAD AND REMOVABLE BOWL	

CHAP. 7 - MAINTENANCE

page 20

- 7.1 - GENERAL
- 7.2 - TIGHTENING THE TOP CHAIN
- 7.3 - GREASING THE CHAINS
- 7.4 - POWER CABLE
- 7.5 - LONG PERIODS OF INACTIVITY
- 7.6 - PUSH BUTTON PANEL LABEL

CHAP. 8 - DISMANTLING

page 21

- 8.1 - PUTTING OUT OF ORDER
- 8.2 - WEEE Waste electrical and electronic equipment

CHAP. 9 - WIRING DIAGRAMS

page 21

- 9.1 - Single phase 230V. - Three phase 230 V. - Three phase 400V.
- 9.1.1 - Voltage selection 230V. Single phase
- 9.1.2 - Voltage selection 230V. Three phase
- 9.1.3 - Voltage selection 400V. Three phase
- 9.1.4 - Select voltage 400V. Three phase 2 speed - mod. 2V
- 9.1.5 - Inverter with diverter - mod. 2V
- 9.1.6 - Inverter with potentiometer - mod. VV

CHAP. 1 - RECEIVING THE MACHINE

1.1 - PACKAGING

The packaging within which the dough mixer is sent is made up of (Fig. n°1): a cardboard box, a wooden pallet and protective nylon. They are to be disposed of separately and in compliance with the existing laws in force in the Country of installation.

	Dimensions AxBxC (mm)	Gross Weight (Kg)
HRC 20	530x830x1020	84
HRC 20 TA	530x830x1020	98
HRC 30	530x830x1020	133,5
HRC 30 TA	530x830x1020	148
HRC 40	630x970x1070	138,5
HRC 40 TA	630x970x1070	153
HRC 50	630x970x1070	168
HRC 50 TA	630x970x1070	183

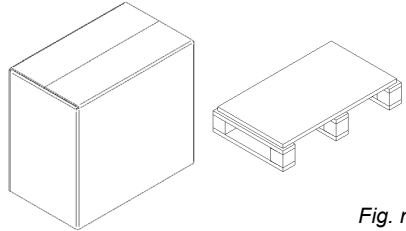

Fig. n°1

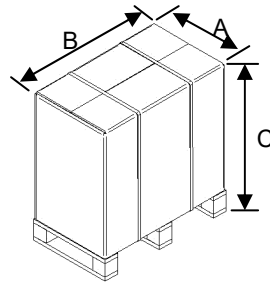

Fig. n°2



ATTENTION!

Do not superimpose two packages of the same type (Fig. n°3).

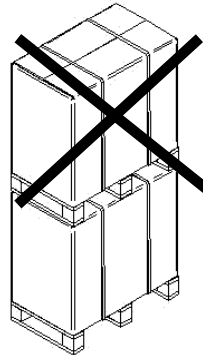

Fig. n°3



Do not expose the package to humidity and rain (Fig. n°4).

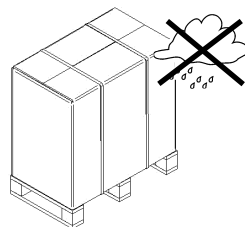

Fig. n°4



Heavy package. Manually lift with the aid of minimum three people (*Fig. n°5*).

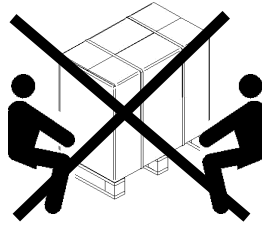

Fig. n°5



Move the package only with electrical or manual trolleys equipped with lifting brackets (*Fig. n°6*).

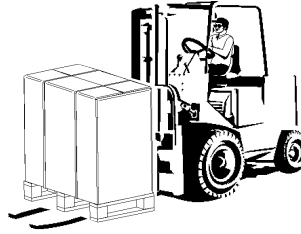

Fig. n°6



Do not move the pack hung from ropes or similar systems because the barycentre is not in the middle (*Fig. n°7*).

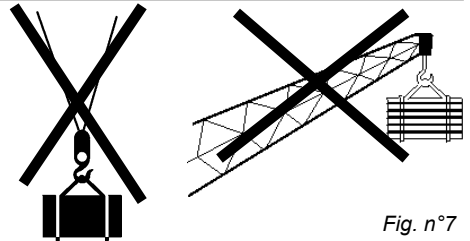

Fig. n°7

1.2 - PACKAGING CHECK ON RECEIPT OF THE PACKAGE

On receiving the package if this shows no signs of external damage, open it and check that all the material is inside. If however on receiving the package there are signs of maltreatment, (*Fig. n°8*), collisions or falls, it is necessary to inform the courier of the damage and within 3 days from the shipping date indicated on the documents, draw up a precise report of the damages caused to the machine. **Do not turn the package upside down!!** When handling make sure that it is held firmly in the four fundamental points (keeping it parallel to the pavement).

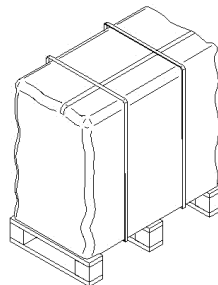

Fig. n°8

CHAP. 2 - INSTALLATION



ATTENTION!

All operations must be carried out by specialised staff (Fig. n°9).



Fig. n°9

2.1 - UNPACKING

1. Remove the strips from the packaging (Fig. n°10) and lift (h) the cardboard box to the pallet.

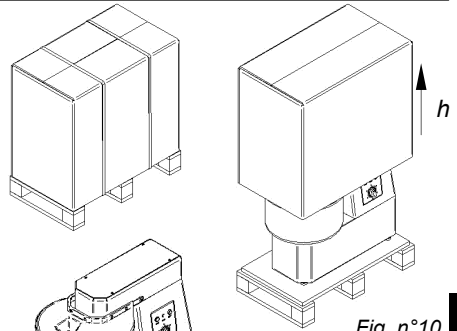

Fig. n°10

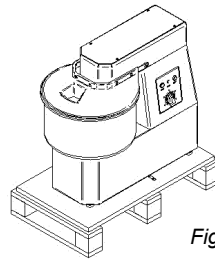

Fig. n°11

2.2 - POSITIONING

Position the pallet, with the dough mixer, on a flat surface and unscrew (a) the screws that fix the machine to the pallet (Fig. n°12). At this point, with care, turn the machine over onto one side and unscrew the screws to remove the anchoring plates (b). Fix the screws removed onto the bottom cover. Position the dough mixer in the pre-destined place.

The surface on which the dough mixer is to be positioned must take into consideration the dimensions indicated in Tab. 1 (based on the model) therefore the support surfaces must be wide enough to contain it (Fig. n°13) and must be well levelled and dry away from water and heat sources with suitable ventilation and lighting in relation to the space necessary for its use and safe keeping.

(The machine must also be positioned in a non saline room with a maximum humidity of 75% and a temperature included between +5°C and +35°C; however in rooms that can not cause malfunctioning of the machine (Fig. n°14).

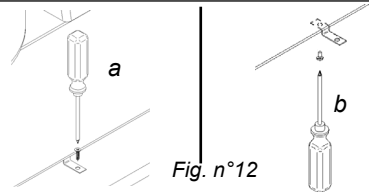

Fig. n°12

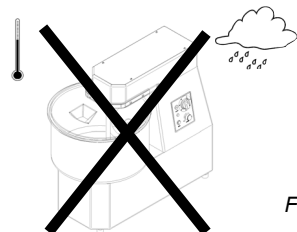
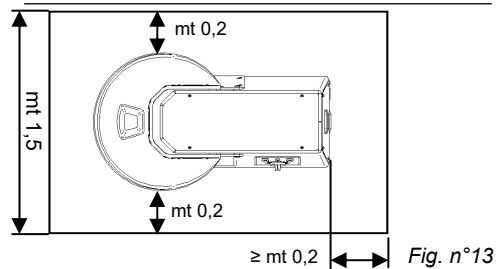

Fig. n°14

English

2.3 - ELECTRIC CONNECTION

Check that the data reported on the technical plate-serial number (*Fig. n°15*), on the dispatch note and in the order carried out correspond; If this is not the case, immediately contact the manufacturer for an explanation.

Make sure at this point that the plant is up to standards and that the cable and the earth plant function perfectly.

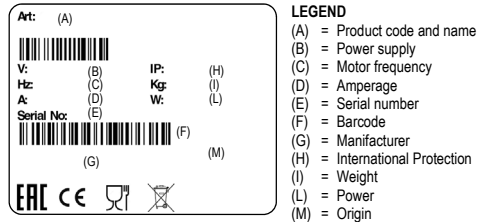

Fig. n°15

2.3.1 - Dough mixer with single phase motor

The dough mixer is provided with a power cable with a 3x1mm² section , 1.5m long and a “SHUKO” plug. Connect the dough mixer to a 230 V. - 50 Hz power source, inserting a residual current device of 10A, $\Delta I= 0.03A$.

2.3.2 - Dough mixer with three phase motor 400 V.

The dough mixer is provided with a power cable with a 5x1mm² section, 1.5m long and a CEI 15A 3F + T red plug. Connect the dough mixer to the three phase 400V. - 50Hz power source, inserting a residual current device of 10 A, $\Delta I=0.03A$.

2.3.3 - Tank rotation direction

Check the tank rotation direction using the “START” button followed straightaway by the “STOP” button.

The tank rotation direction must be clockwise looking at the dough mixer from above (Fig. n°16). If the rotation direction is not correct, invert (Fig. n°17) the position of two of the three phase wires in the plug (black, grey or brown).

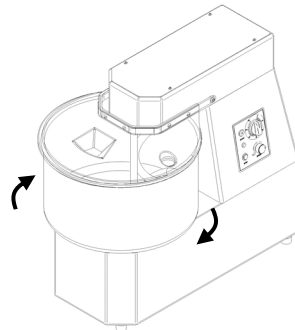

Fig. n°16

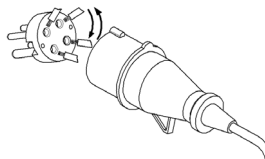

Fig. n°17

2.3.4 - Dough mixer with three phase motor 230 V.

The dough mixer is provided with a power cable with a 5x1mm² section, 1.5m long and a CEI 15A 3F + T blue plug;

Connect the dough mixer to the three phase 230 V. - 50 Hz, power source, inserting a residual current device of 10A, $\Delta I= 0.03A$.

Check that the rotation direction of the mixing blade is anti-clockwise looking at the dough mixer from the guard side. On the contrary, proceed as for **par. 2.3.3**.

2.4 - PRELIMINARY CHECKS

Before testing make sure that the protection located on the tank is lowered up to slightly touching the bowl (Fig.No.18 - ref.a), after which test functioning as follows:

Controls key (see Fig. 19):

1. START button
2. STOP button
3. Power light
4. TIMER knob
5. Two-speed switch knob (2V)
6. Variable speed knob (VV)

Fig. No. 18-19-20

- A) Activate the "START" button (1) and the "STOP" button (2).
- B) Check that when lifting the protection (a) the machine stops functioning.
- C) Check if the machine is on, remove the plug and reinsert it to check if the machine does not automatically restart.
- D) In the liftable head (TA) and removable bowl versions, check if the machine stops running when the head is unlatched (Fig. No. 20 - ref.b);
- E) Optional TIMER efficiency check TIMER optional (4).
- F) For double speed models (2V) select speeds 1 or 2 by rotating the selector switch (5) and pressing the "START" button (1); press the "START" button (1) each time the speed is changed.

We recommend periodically checking points B, C and D. In the event of malfunctions, do not use the machine but pull out the plug and contact the SERVICE CENTRE.

In models with a liftable head (TA), make sure that the head (b) and guard are lowered. The head must be horizontal and the locking knob must be pointed down (Fig. No. 20).

Verify that the bowl is correctly inserted and locked by the disc.

After these operations have been completed, it is possible to begin the functional verification as described above.



ATTENTION!

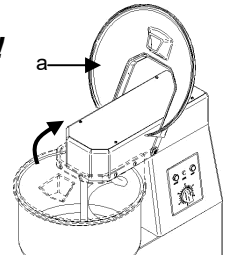

Fig. n°18

Controls:

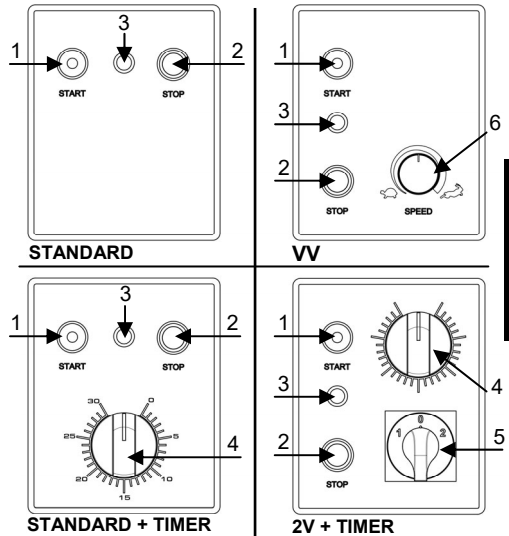

Fig. n°19

English



ATTENTION!

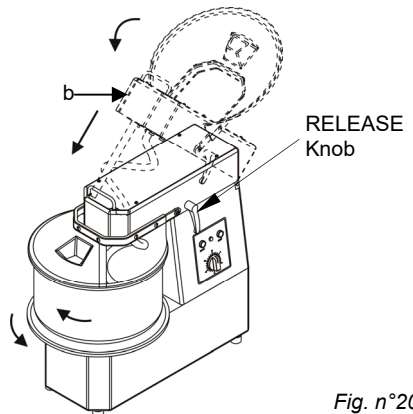

Fig. n°20

CHAP. 3 - INFORMATION REGARDING THE MACHINE

3.1 - GENERAL PRECAUTIONS

The general precautions, even if taken for granted, are fundamental for installation, use maintenance and any inconveniences with respective solutions.

- The dough mixer has been projected for mixing and blending flours for food use. Every other use is to be considered improper and therefore dangerous.
- The Manufacturer cannot be held responsible in the following cases:
 - ⇒ **if the machine is tampered with by non authorised staff;**
 - ⇒ **if components are replaced with non original ones;**
 - ⇒ **if the instruction in this manual are not carefully followed;**
 - ⇒ **if the machine surfaces are treated with non suitable products.**

- Conserve this manual with care for future information or reference (Fig. n°21).
- The dough mixer must be used only by trained staff with perfect knowledge of the safety standards contained in this manual.
- If staff turnover is necessary, provide training beforehand.
- The dough mixer must not be used by children or incompetent persons and however by non trained persons (Fig. n°22).
- Disconnect the machine's socket from the electric network before carrying out any cleaning or maintenance operations.
- Carefully valuate the residual risks when intervening for routine dough mixer maintenance or cleaning (therefore the tank protection is lifted).
- During maintenance or cleaning remain concentrated on the operations in progress.
- Do not use corrosive or flammable substances to clean the dough mixer (Fig. n°23).
- To clean, carefully follow the instructions in the "Routine cleaning" chapter.
- Do not wash the dough mixer with jets of water, with rough or abrasive means that can ruin the surfaces. Do not immerge it in water or other liquids.
- Do not expose the dough mixer to damaging agents: sun, rain, splashes,



ATTENTION!



Fig. n°21

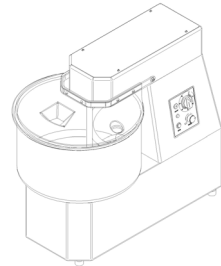

Fig. n°22



ATTENTION!

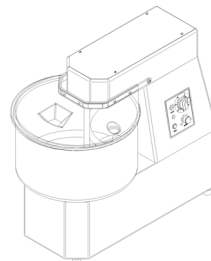

Fig. n°23

humidity, ice (Fig. n°24).

- Do not pull the dough mixer or the power cable (Fig. n°25), to disconnect the plug from the socket.
- Regularly check the state of the power cable; a worn cable or however not integral is a serious electrical .
- If the machine is not used for a long period of time, contact the “After Sales Centre” for a test before use.
- If the machine should assume or show signs of malfunctioning, it is recommended that it is not used and do not intervene directly for repairing but contact “After sales centre”, visible on the back of this manual.
- Do not leave the dough mixer insert if not necessary. Pull out the plug when the machine is not being used.
- Even if the machine has safety systems installed on the dangerous points, do not place hands, arms or any other part of the body near to the tank and the moving parts inside it.

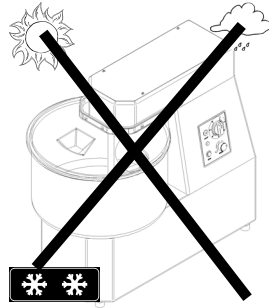

Fig. n°24

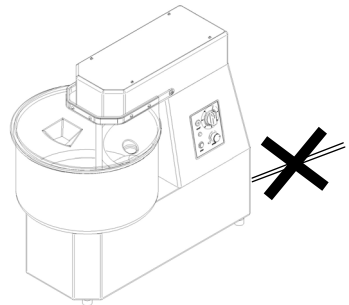

Fig. n°25

CHAP. 4 - LEARNING ABOUT THE DOUGH MIXER

4.1 - CONSTRUCTIVE CHARACTERISTICS

The dough mixer is mainly made up of a large thick C40 steel structure protected with scratch resistant powder coating. This guarantees contact with foodstuff (hygiene).

The tank with reinforced edge, the forged spiral tool and the shaft are made from AISI 304 stainless steel. The protection placed on the tank, conforming to standards, is made of PETG with a hole for adding products during processing (an AISI 303 steel protection grill is available upon request).

The machine is designed and manufactured exclusively for mixing pizza dough, consisting of flour, water, salt, yeast and oil at room temperature.

Remove the dough from the bowl immediately after the work cycle.

Do not leave the dough to leaven inside the bowl.

The transmission is a high efficiency motor with oil bath gear box and the moving parts are mounted on watertight ball bearings. The controls are low voltage IP 67. Wheels and timer are optional.

4.1.1 - machine set-up with fixed head and bowl

LEGEND:

- | | |
|------------------|--|
| 1 Frame | 7 Tank lid |
| 2 Spiral | 8 Tank protection |
| 3 Controls panel | 9 Foot |
| 4 Top sump | 10 Terminal board |
| 5 Shaft | 11 Rear sump |
| 6 Tank | 12 Thermal overload protection circuit breaker |

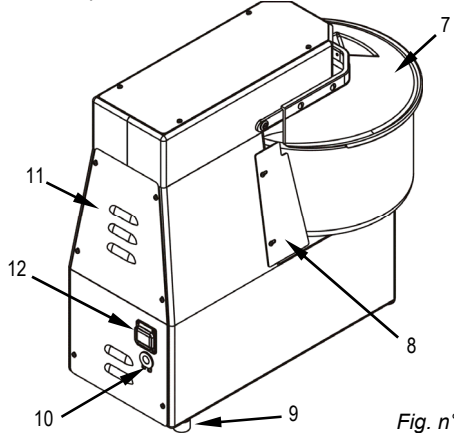
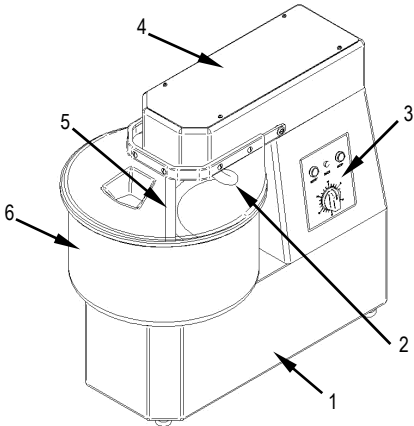

Fig. n°26

4.1.2 - machine set-up with liftable head and removable bowl

LEGEND:

- | | |
|------------------|--|
| 1 Frame | 8 Tank protection |
| 2 Spiral | 9 Foot |
| 3 Controls panel | 10 Terminal board |
| 4 Top sump | 11 Rear sump |
| 5 Shaft | 12 Bowl locking disc |
| 6 Tank | 13 Release knob |
| 7 Tank lid | 14 Thermal overload protection circuit breaker |

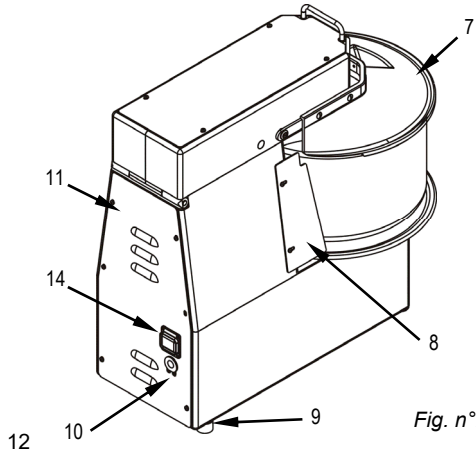
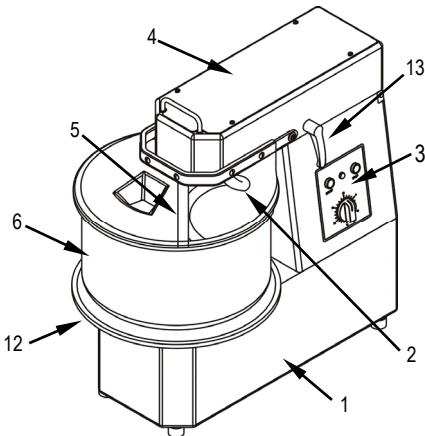

Fig. n°27

4.2 - SAFETY SYSTEMS INSTALLED ON THE MACHINE

4.2.1 - Mechanical safety systems

Regarding the mechanical safety systems, the dough mixer described in this manual responds to:

- the **EEC 2006/42** Machine Directives.

The safety systems are:

- Lid for rotating tank
(Fig. n°28 ref. n°1);
- Tank protection
(Fig. n°28 ref. n°2).

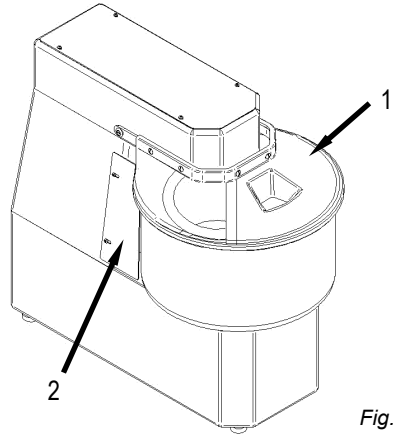

Fig. n°28

English

4.2.2 - Electrical safety systems

Regarding the electrical safety systems, the dough mixer described in this manual responds to:

- the low voltage directive **EEC 2006/95**;
- the electromagnetic compatibility directive **EEC 2004/108**

The dough mixer is envisioned with:

- thermal protection circuit breaker with manual reset, on back of machine, which stops the machine when current overload or motor jamming occur (Fig. n°29).

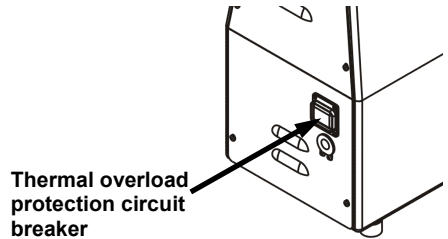

Fig. n°29

- A micro switch on the protection, located on the tank, that stops the machine if it is lifted and does not allow switch on unless the protection is closed (Fig. n°30).

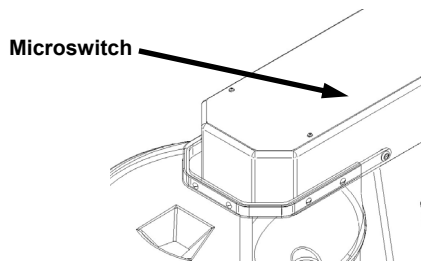

Fig. n°30

- Relay in the control circuit that requires restarting the machine in case of accidental lack of power supply (*Fig. n°31*).

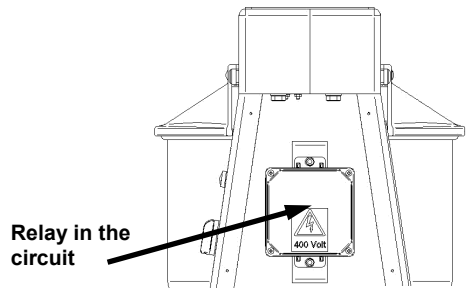

Fig. n°31

For the liftable head and removable bowl versions:

- a microswitch on bowl guard and head release, causes the machine to stop when the guard is lifted or the head is released (*Fig. No. 32*);
- a proximity sensor that detects if the bowl is in position or has been removed (*Fig. No. 32*).

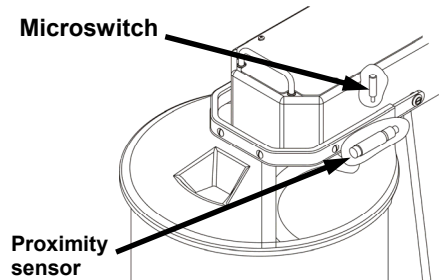

Fig. n°32

Even though the **CE** professional dough mixers are equipped with regulation measures for electrical and mechanical protections (both during functioning and during cleaning and maintenance), there are however **RESIDUAL RISKS** that cannot be totally eliminated and are recalled in this manual under the form of **ATTENTION**. These relate to danger of contusions or other caused by the tank or other machine components.

4.3 - DESCRIPTION OF THE MACHINE

The **CE** professional dough mixers have been projected and realised by our company with the precise purpose of mixing food products (flour, yeast etc.) and guarantee:

- maximum safety during use, cleaning and maintenance;
- Maximum hygiene, obtained thanks to the meticulous selection of materials that come into contact with food stuff;
- robustness and stability of all components.

4.4 - MACHINE NOISE LEVEL

The measurement of the noise level indicates that the value is 60 dB.

4.5 - OVERALL SIZE, WEIGHT, CHARACTERISTICS

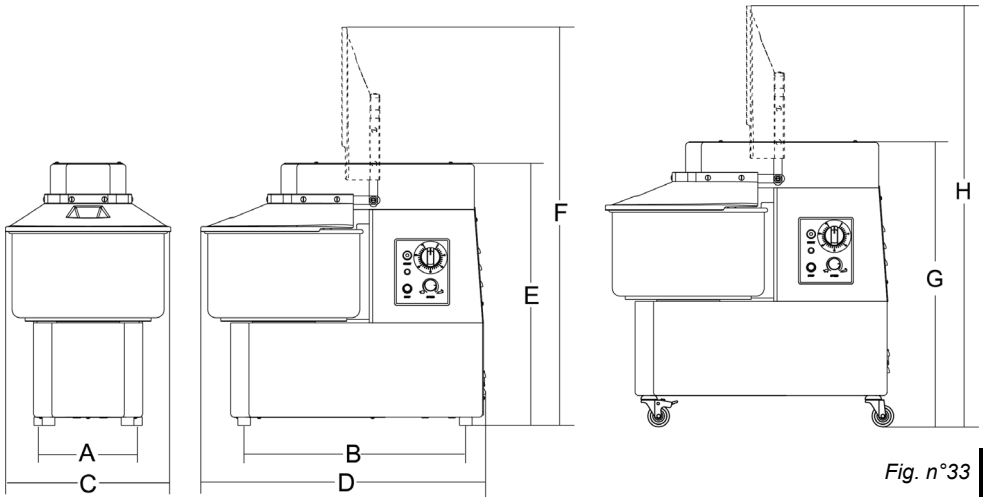

Fig. n°33

TAB.n°1 - OVERALL MEASUREMENTS AND TECHNICAL CHARACTERISTICS

MODEL	U.m.	HRC 20 HRC 20 VV HRC 20 2V	HRC 30 HRC 30 VV HRC 30 2V	HRC 40 HRC 40 VV HRC 40 2V	HRC 50 HRC 50 VV HRC 50 2V
Tank dimensions	mm	ø360 x 210	ø400 x 260	ø452 x 260	ø500 x 270
A x B	mm	230 x 530	270 x 590	310 x 660	310 x 680
C x D	mm	390 x 680	440 x 740	480 x 825	540 x 880
E / F	mm	625 / 950	700 / 1050	730 / 1135	750 / 1205
G / H	mm	705 / 1030	780 / 1130	810 / 1215	830 / 1285
Tank capacity	lt	21	32	41	52
Dough capacity	kg	17	25	32	44
Motor 2V and VV motor	W	750 750/1.100	1.100 1.300/1.700	1.500 1.500/2.200	1.500 1.500/2.200
Bowl rotations Bowl rotations VV Bowl rotations 2V	r.p.m	10 10÷20 10/20	10 10÷20 10/20	10 10÷20 10/20	10 10÷20 10/20
Spiral rotations Spiral rotations VV Spiral rotations 2V	r.p.m	85 85÷170 85/170	85 85÷170 85/170	85 85÷170 85/170	85 85÷170 85/170
Net weight	Kg	72	118,5	123,5	149
Power Source Power Source VV Power Source 2V		230-400 V / 50 Hz 230 V / 50 Hz 400 V / 50 Hz			
Noise degree	dB	≤ 60			

English

Models TA

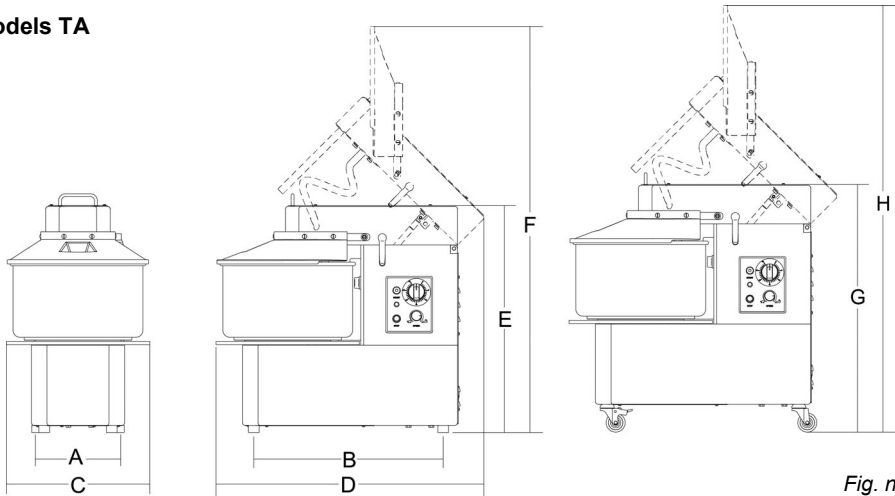

Fig. n°34

TAB.n°2 - OVERALL MEASUREMENTS AND TECHNICAL CHARACTERISTICS

MODEL	U.m.	HRC TA 20 HRC TA 20 VV HRC TA 20 2V	HRC TA 30 HRC TA 30 VV HRC TA 30 2V	HRC TA 40 HRC TA 40 VV HRC TA 40 2V	HRC TA 50 HRC TA 50 VV HRC TA 50 2V
Tank dimensions	mm	ø360 x 210	ø400 x 260	ø452 x 260	ø500 x 270
A x B	mm	230 x 530	270 x 590	310 x 660	310 x 680
C x D	mm	400 x 751	440 x 823	490 x 910	540 x 970
E / F	mm	635 / 1125	710 / 1.260	740 / 1.360	795 / 1.415
G / H	mm	715 / 1205	790 / 1340	820 / 1440	875 / 1495
Tank capacity	lt	21	32	41	52
Dough capacity	kg	17	25	32	44
Motor 2V and VV motor	W	750 750/1.100	1.100 1.000/1.400	1.500 1.500/2.200	1.500 1.500/2.200
Bowl rotations Bowl rotations VV Bowl rotations 2V	r.p.m	10 10÷20 10/20	10 10÷20 10/20	10 10÷20 10/20	10 10÷20 10/20
Spiral rotations Spiral rotations VV Spiral rotations 2V	r.p.m	85 85÷170 85/170	85 85÷170 85/170	85 85÷170 85/170	85 85÷170 85/170
Net weight	Kg	88	133	138	164
Power Source Power Source VV Power Source 2V		230-400 V / 50 Hz 230 V / 50 Hz 400 V / 50 Hz			
Noise degree	dB	≤ 60			

ATTENTION:

The electrical characteristics for which the machine is prepared are indicated on the plate at the back of the machine.

CHAP. 5 - USING THE MACHINE

5.1 - STARTING UP THE MACHINE

For 1st use strictly follow the following instructions:

- check that installation has been carried out correctly as indicated in **chapter 2**;
- lift the tank's lid (*Fig. 35*) and pour inside the tank all of the water and other liquids necessary for the dough;
- add about 50% of the flour and the other solid ingredients (*Fig. 36*);
- close the lid by lowering it up to slightly touching the tank;
- check before any other operation that the main switch is ON;
- before switch on, check the voltage of the distribution network by means of switch on of the "NETWORK" warning light (*Fig. 37*);
- press the "START" button to start the machine that will start the work cycle;
- after 2-3 minutes stop the machine by pressing the "STOP" button;
- lift the lid and insert the remaining flour;
- close the lid and start the machine that will blend all ingredients, transforming it into a homogeneous dough;
- a thermal overload protection circuit breaker stops the machine in case of a motor jamming. After removing its cause, you can reset the protection and restart the machine in few minutes.
- at the end of the cycle, the dough will detach from the tank walls, therefore stop the machine;
- if need be, to slightly modify the characteristics of the dough without stopping the machine, pour in the ingredients using the opening on the tank protection (*Fig. 38*)
- Before lifting the protection and removing the dough to be placed on the work bench, pull the plug out of the socket.

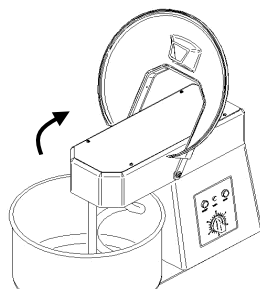

Fig. n°35

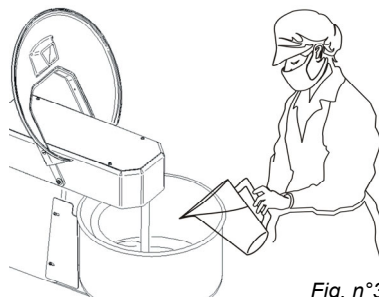

Fig. n°36

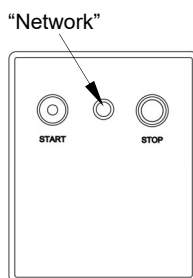

Fig. n°37

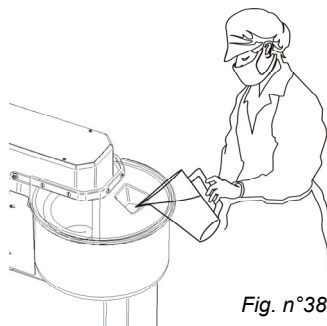

Fig. n°38



ATTENTION!

English

5.2 - MACHINE WITH LIFTABLE HEAD AND REMOVABLE BOWL

Machines with liftable head and removable bowl, though basically working the same as the fixed head and bowl versions, differentiate themselves because of what they can offer at the end of each work cycle:

- Easier emptying of the bowl.
- Saving time in the cleaning phase.

For machine use proceed as described in paragraph 5.1 and at the end of each cycle complete these steps (*Fig. No. 39*):

- After stopping the machine and unplugging the power supply cable, lift the bowl guard completely
- Rotate the release knob until the head is unlocked
- Lift head using the piston below it
- Take out the dough and place it on the worktop.
- If necessary, remove the bowl to facilitate cleaning operations.

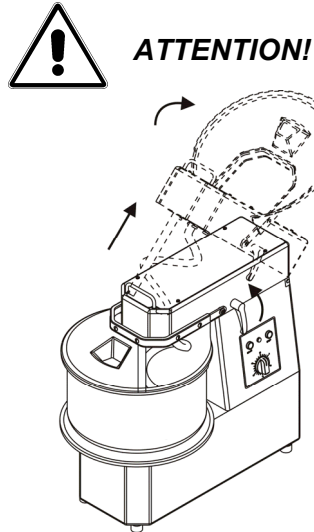

Fig. n°39

5.3 - PRODUCTIVITY AND DURATION OF THE PRODUCTION CYCLE

For each model that maximum production capacity for each cycle is indicated as in *Tab. 1-2*.

The duration of the work cycle, in relation to the machine model, can vary from about 14 to 20 minutes.

In models with a timer the work time can be set from 1 to 30 minutes, rotating the knob (*Fig. n°40*) to the desired position and starting the machine. When the prefixed time limit is reached, the timer stops the machine.

Do not exceed the quantity of dough that the machine can produce in each operational cycle indicated also in *Tab. 1-2* (depending on the model).

Adding water and other ingredients to the mass already partially mixed inside the tank must be carried out gradually to the indicative proportion of about 2 Kg of flour for each litre of liquid.

Pour first the water then the flour into the tank.

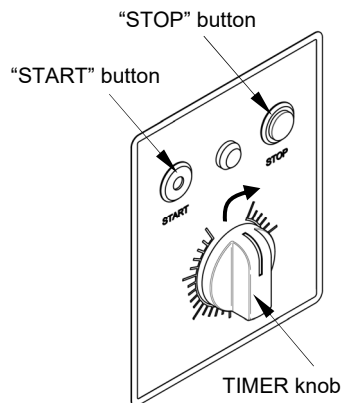

Fig. n°40



ATTENTION!

CHAP. 6 - ROUTINE CLEANING

6.1 - GENERAL

- the machine must be cleaned at least once a day or if necessary, more frequently.
- all dough mixer parts that come into direct or indirect contact with the processed foodstuff must be scrupulously cleaned.
- Do not use hydro cleaners, high pressure water jets but neutral detergents (pH 7) to clean the dough mixer **Any other product is forbidden**. Do not use tools, brushes and other than can superficially damage the machine.

Before carrying out any cleaning operation:

- Disconnect the plug to fully isolate the machine from the rest of the plant.

6.2 - CLEANING THE MACHINE

The tank, the shaft and the spiral must be cleaned at the end of each working cycle and must be carried out using hot water and a sponge. Carefully dry each element at the end of the cleaning operation.

Use a sponge wet slightly with a small amount of detergent and non harmful sanitizer to clean the outside of the machine.

Do not use abrasive detergents, detergent creams, solvents or diluents; residuals of these products can dangerously contaminate the foodstuff during successive processing.

Do not use abrasives or metallic chaffs to prevent damaging the surfaces by scratching.



ATTENTION!



Fig. n°41

6.3 - MACHINE WITH LIFTABLE HEAD AND REMOVABLE BOWL

After removing all the dough, as described in Paragraph 5.2, carry out the following operations to clean the tank (Fig. 42):

- Rotate the disc clockwise to unlock the bowl
- Lift and remove the bowl
- clean the tank.

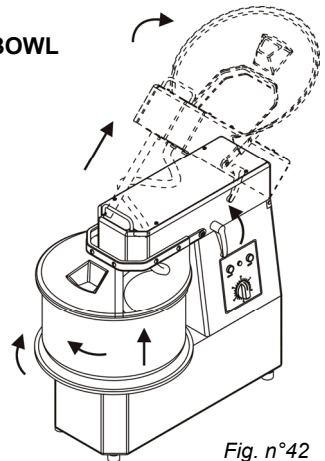

Fig. n°42

The tank must be removed only when empty.

After terminating the cleaning operations, dry the tank carefully and put it back on while making sure that the four underlying pins are correctly inserted through the holes of the disc, then turn the latter anti-clockwise (Fig. 43).

Reposition the head horizontally by pushing it to lower it progressively.

Rotate the release knob to lock it into position.

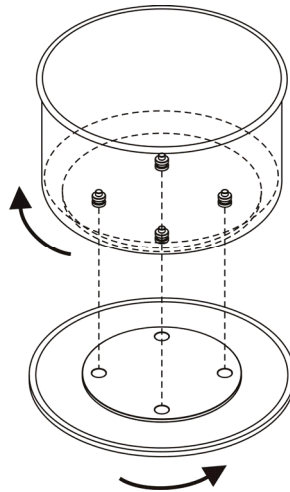

Fig. n°43

CHAP. 7 - MAINTENANCE

7.1 - GENERAL

Before carrying out any maintenance operation it is necessary that the plug be disconnected from the network in order to isolate completely the machine from the rest of the plant.

7.2 - TIGHTENING THE TOP CHAIN

The chain must be tightened if, when carrying out excessive checks it is loose or if spiral rotation is not constant. In this case call the "AFTER SALES CENTRE" for retightening.

7.3 - GREASING THE CHAINS

It is recommended that both drive chains be greased periodically using suitable grease to guarantee lubrication of all chain links.

7.4 - POWER CABLE

Periodically check the wear of the cable and if necessary call the "AFTER SALES CENTRE" to replace.

7.5 - LONG PERIODS OF INACTIVITY

If having to leave the machine inactive for a long period of time, carefully clean and sanitize the machine. Protect it from dust using a clean dry cloth that can fully cover up to the base.

7.6 - PUSH BUTTON PANEL LABEL

Over time the push button panel could become marked and/or pierced. In this case call the "AFTER SALES CENTRE" to replace.

CHAP. 8 - DISMANTLING

8.1 - PUTTING OUT OF ORDER

If for any reason the machine is put out of order, make sure that it cannot be used by anybody: **disconnect the electric connections.**

8.2 - WEEE Waste electrical and electronic equipment



The crossed out waste bin symbol on the appliance indicates that the product must be disposed of separately from other refuse at the end of its working life.

Differential collection of this present appliance at the end of its working life has been organised and managed by the manufacturer. The user must therefore contact the manufacturer and follow the system been adopted to allow differential collection at the end of its working life.

Suitable differentiated collection, followed by eco-friendly processing and disposal, contribute to preventing potential damage to the environment and health, encouraging the reuse and recycling of the materials of which the appliance is comprised.

Incorrect disposal of the appliance by the user may entail the application of administrative penalties as stated in the relevant Legislative Decree.

English

CHAP. 9 - WIRING DIAGRAMS

9.1 - Single phase 230V. - Three phase 230 V. - Three phase 400V.

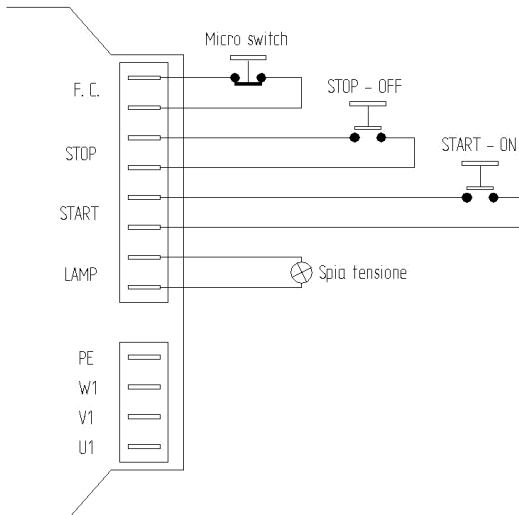

Fig. n°44

9.1.1 - Voltage selection 230 V. Single phase

Alimentazione/power supply F + N: 220 - 240 V 50 Hz

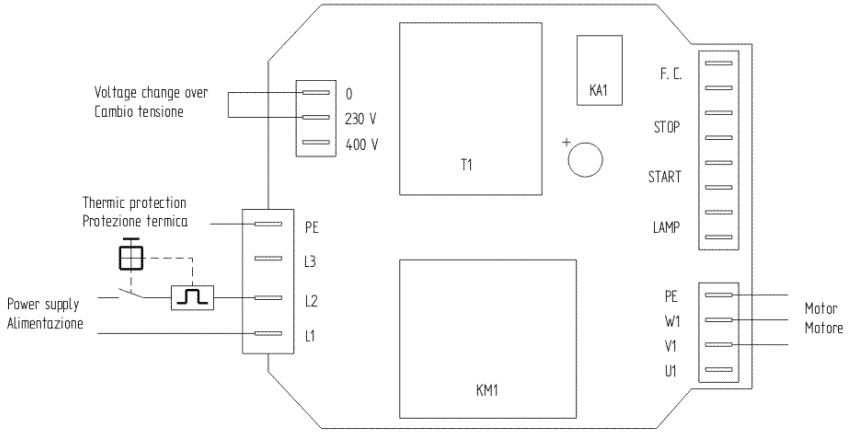

Fig. n°45

9.1.2 - Voltage selection 230 V. Three phase

Alimentazione/power supply 3F + T: 230 V 50 Hz

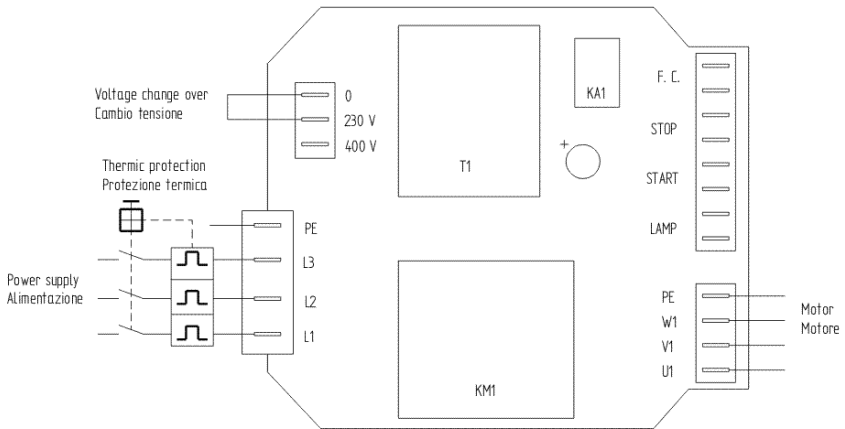

Fig. n°46

9.1.3 - Voltage selection 400 V. Three phase

Alimentazione/power supply 3F + T: 400 V 50 Hz

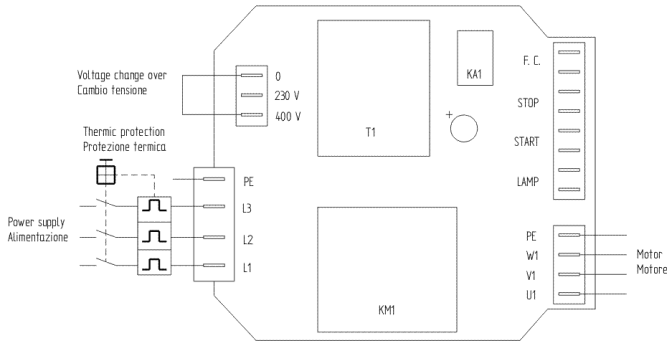

Fig. n°47

9.1.4 - Voltage selection 400 V. Three phase 2 speed - mod. 2V

Alimentazione/power supply 3F + T: 400 V 50 Hz

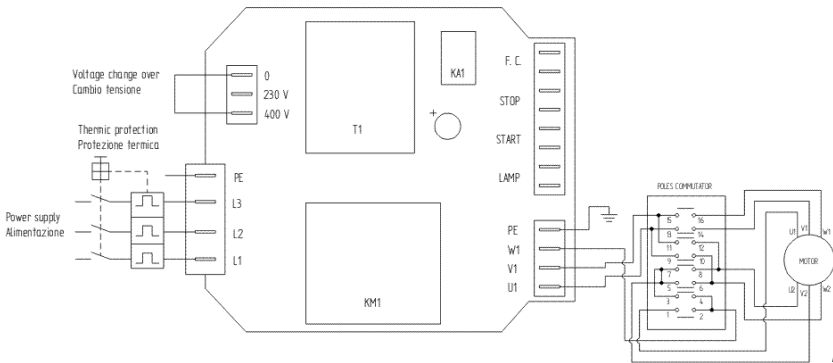

Fig. n°48

9.1.5 - Inverter with diverter - mod. 2V

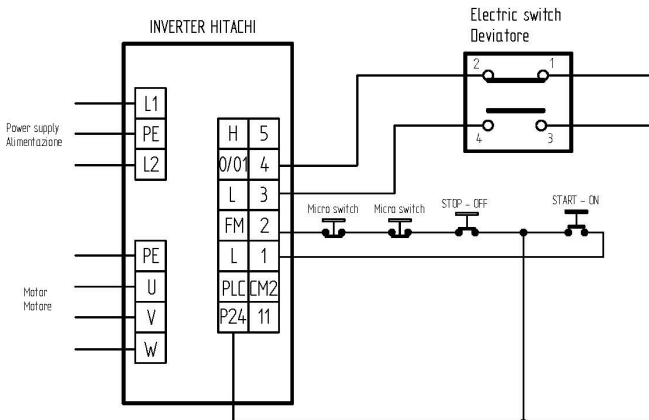

Fig. n°49

9.1.6 - Inverter with potentiometer - mod. VV

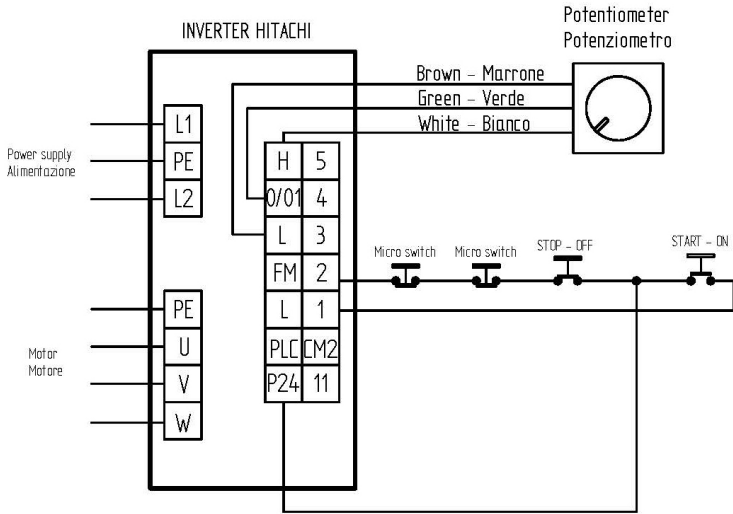

Fig. n°50

**AFTER SALES CENTRE
AUTHORISED DEALER**