



# SIRPASTA XP

## macchine per la pasta fresca

### *pasta machine*



YouTube



76

- Impasto facile e veloce con il sistema spirale planetaria che permette di idratare perfettamente tutto l'impasto
- Vasca e spirale facilmente smontabili per pulizia e sanificazione
- Efficiente motore ventilato assicura una produttività costante e continua
- Pulsanti inox IP 67
- Coperchio con interblocco di sicurezza
- Coclea e corpo bocca in acciaio inox

**Opzionali:**

- Motorino tagliapasta con variatore di velocità
- Motorino tagliapasta automatico con regolazione di velocità e tempo
- Compatibile con Raviolatrice RAVIOMATIC
- Trafile in bronzo con ampia disponibilità di formati
- Pastastation
- SRCS scheda controllo remoto



78

- *Easy and fast mixing with the planetary spiral system which allows you to hydrate the whole mix perfectly*
- *Bowl and spiral easily removable for cleaning and sanitizing*
- *Efficient, fan-cooled motor ensures constant, non-stop productivity*
- *IP 67 stainless steel buttons*
- *Lid with safety interlock device*
- *Feeder screw, opening unit made of stainless steel*



80

**Options:**

- *Variable-speed pasta cutter*
- *Automatic pasta cutter with adjustable speed and timer*
- *Compatible with the RAVIOMATIC ravioli maker*
- *Bronze dies with wide availability of formats*
- *Pastastation*
- *SRCS wifi control board*

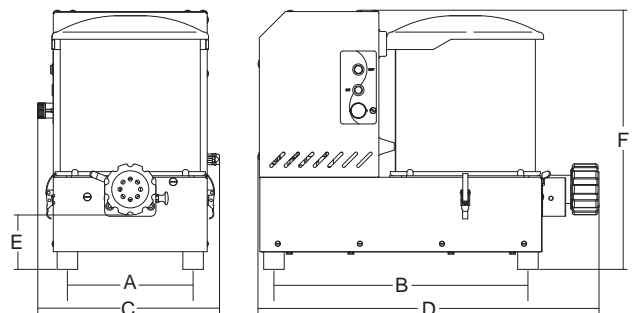
**Optionals**Tagliapasta  
Pasta cutterTagliapasta automatico  
Automatic pasta cutterChiusura bocca per impasto  
Gate closure for mixingVaschetta per liquidi  
Liquid distribution hopper

watt/HP

lt

kg

ø mm

mm

mm

mm

mm

mm

mm

kg

mm

kg

Sirpasta XP

750/1

1ph

20

4.2

75

245

495

354

665

106

505

52

760x640x740

67