

8 - Trouble-Shooting

8.1 - Trouble-shooting

Problem	Cause	Solutions
The machine does not start up	The differential switch is positioned to "0".	Bring the switch to "I" position
	The main switch is positioned to "0"	Bring the switch to "I" position
	The start up button is faulty	Contact the Technical Assistance
	Safety devices not present or incorrectly mounted	Check the safety devices and protections
The fun is nor working	The motor must still reach 60°	It is not a problem
	The bimetal switch has broken	Contact the Technical Assistance
	The fun got burnt out	Contact the Technical Assistance
The dough does not flow out	The extruder is dirty	Clean the extruder
	The machine is running in mixing mode	Shut the machine down and push the extruding mode button

**SERVICE CENTRE
AUTHORISED RETAILER**

PASTA EVO

Fresh pasta machine

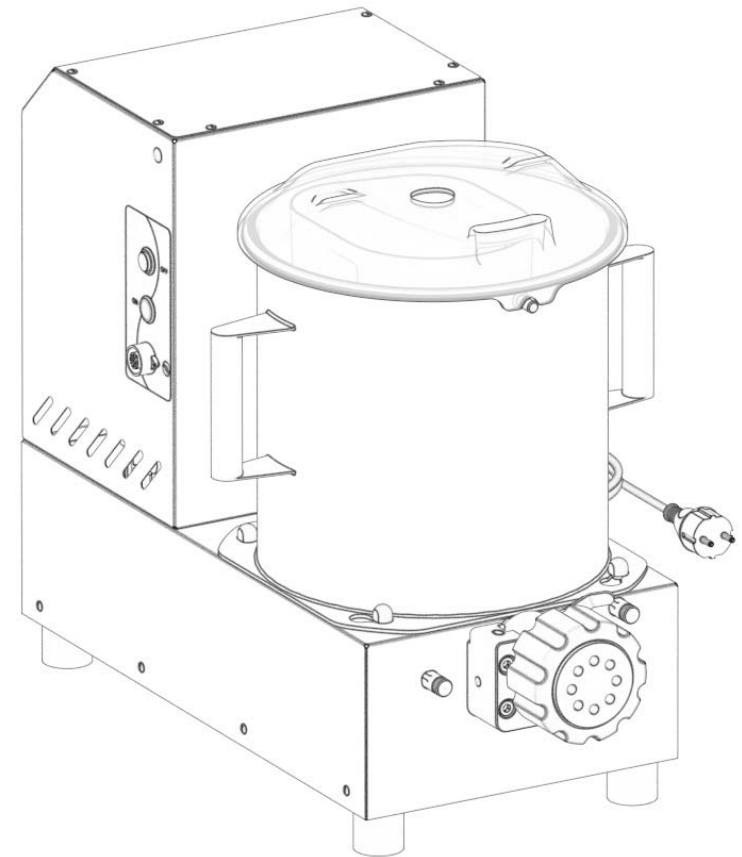

Ed. 001 - 04/2018

INSTRUCTIONS, USE AND MAINTENANCE MANUAL

7.4 - Waste Electrical and Electronic Equipment WEEE



Pursuant to article 13 of the Legislative Decree n. 151, July 25th, 2005 "implementation of Directive 2002/95/EC, 2002/96/EC and 2003/108/EC, related to the restrictions on the use of hazardous substances in electrical and electronic equipment, as well as waste disposal"

The crossed bin symbol on the device or its packaging indicates that, at the end of their life, the product must be collected separately from other waste.

The separate collection at the end of this machinery life is organized and managed by the manufacturer. The user who wishes to dispose of this equipment must contact the manufacturer and follow the procedure adopted to allow separate collection at the end of life.

Appropriate separate collection and subsequent decommissioning for recycling, treatment and environmentally compatible disposal helps prevent negative impact on the environment and health, and promotes the reuse and / or recycling of materials the equipment is made of.

Illegal disposal of the product involves application of administrative sanctions provided by law.

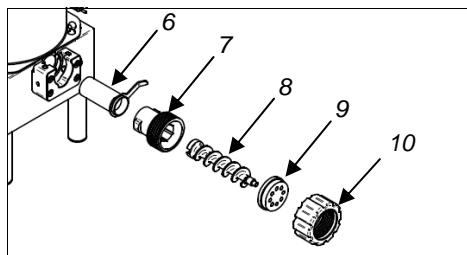

WARNING!

After each kneading, ensure the propelling pivots are thoroughly cleaned so the blade and Archimedean screw can be properly assembled (fig 7.2.2)

CONTENTS

1.	Delivery and warranty	4
1.1	Foreword	
1.2	Preserving and using the manual	
1.3	Warranty	
1.4	Description of the machine	
1.5	Permitted use	
1.6	Improper use not permitted	
1.7	Identification of the equipment	
1.7.1	Warning plates	
1.8	Safety devices and protections	
1.9	Operating station	
2.	Technical features	10
2.1	Main components	
2.2	Technical specifications	
2.3	Dimensions and weight of the machine	
2.4	Noise level	
2.5	Electrical diagrams	
2.5.1	230V / 50 Hz 1 ph	
3.	Controls and indicator lights	13
3.1	List of controls and indicator lights	
4.	Inspection, shipping, delivery and installation	13
4.1	Inspection	
4.2	Shipping and handling the machine	
4.3	Installation	
4.3.1	Disposing of the packaging	
4.3.2	Handling the machine	
4.4	Electrical connections	
4.4.1	Single-phase machine	
5.	Start up and shut down	15
5.1	Checking the electrical connections	
5.2	Checking the presence and effectiveness of safety devices and guards	
5.3	Checking the effectiveness of the emergency button	
5.4	Machine start up	
5.5	Machine shut down	
6.	Using the machine	16
6.1	Instructions	
6.2	Dough preparation	
6.3	Extrusion	
6.4	Using the dough cutter	
7.	Maintenance	17
7.1	Prescriptions	
7.2	Lubrication	
7.3	Cleaning the machine	
7.3.1	Disassembling the tank, spiral, ring and rotor and cleaning the outlet	
7.4	Waste Electrical and Electronic Equipment WEEE	
8.	Trouble-shooting	20
8.1	Trouble-shooting	

1 - Delivery and warranty

1.1 - Foreword

WARNING!

The symbols used in this manual are intended to draw the reader's attention to points and dangerous operations as regards personnel and operators safety as well as the risks to damage the machine.

Do not operate the machine unless you are not certain to have understood properly the meaning of these indications.

WARNING!

For clarity, some illustrations in this Manual show the equipment or parts of it with the panels or casings removed.

Do not use the machine in such conditions. The machine has to be used only when all guards are in place.

This manual cannot be reproduced, even partially, without the consent of the manufacturer and its contents can not be used for purposes not permitted by the manufacturer.

Any violation of the copyright mentioned above could lead to prosecution under law.

1.2 - Preserving and using the manual

The purpose of this manual is to give the users by means of texts and images the recommendations and essential criteria related to transport, handling, use and maintenance of the machine. Read this manual carefully prior to using the machine.

The Manual must be preserved in a known easily accessible place, available for consultation whenever required. If the Manual is lost, damaged or becomes illegible, contact your reseller or directly manufacturer for a copy.

If the equipment concerned changes ownership, the Manual has to be handed over to the new owner.

This manual reflects the state of the techniques at the moment the machine has been placed on the market and it doesn't has to be considered obsolete just because not yet updated according to the new expertise. The manufacturer reserves the right to update the production and related manuals without updating the production and the previous manuals, except for special cases. In case of doubts, please contact the nearest Customer Assistance Service of the manufacturer.

The manufacturer aims to continuously improve its products.

For this reason, the manufacturer is keen to receive any report or proposal aimed at improving the machine and / or the manual. The equipment has been delivered to the user under warranty conditions at the moment of the purchase. Please contact the manufacturer for further details.

1.3 - Warranty

Under no circumstances the user is allowed to tamper with the machine. In case of fault refer to your supplier.

7 - Maintenance

7.1 - Prescriptions

WARNING! All maintenance and cleaning intervention must only be carried out with the machine shut down and disconnected from the mains.

The area where maintenance is performed must always be clean and dry.

Do not allow unauthorized personnel to operate on the machine.

Any possible replacement of components, including the replacement tools, must be carried out with original spare parts by authorized workshops or directly by the manufacturer.

7.2 - Lubrication

The machine does not require lubrication.

7.3 - Cleaning the machine

WARNING!

- Unplug the machine from the mains before cleaning.
- Do not wash the machine with pressurized water jet.
- With a sponge soaked in water and suitable non toxic neutral degreasers (pH 7), remove any residues off the machine.
- At the end of each working cycle for cleaning, remove the following parts.

7.3.1 - Disassembling the tank, spiral, ring and rotor and cleaning the outlet

- Turn the tank counterclockwise (1) and lift it upwards (2).
- Undo the ring (3), then remove the pasta screw (4).
- Slacken off the ring (10) with the provided wrench, then unscrew it by hand until it comes off completely.
- Extract the extruder (9) and screw (7) from the outlet (6).
- Pull the handwheel out (5), rotate the outlet tube and extract it (7).
- Extract the opening/closing tube (6).
- Remove the any pasta residue from inside the outlet port.
- Once all parts are clean and washed, reassemble the machine.

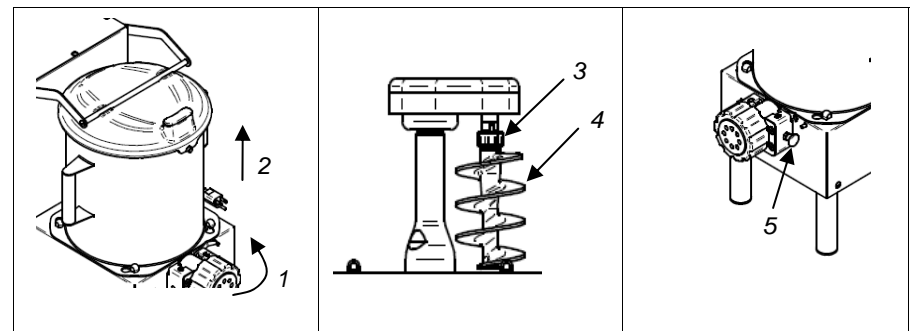

Fig. 7.2.1

6 - Description of the machine

6.1 - Prescriptions

WARNING!

Only authorized personnel can operate on the machine.

Prior to the start up the operator must first ensure all the guards are in place and all the safety devices are present and effective. Otherwise, shut the machine down and contact the operator in charge with maintenance.

Ensure that the of flour / egg ratio is always
1kg of flour / 400g of egg.

Assemble the machine's pasta extruder, screw and blade before starting.

6.2 - Dough preparation

1. Make sure the pasta shutter lever is set to "C"
2. Pour the flour mix in the mixing basin
3. Close the top cover
4. Start the machine mode with button "1" (Fig. 3.1.1)
5. Start pouring the eggs already beaten in the feeder funnel
6. After the eggs where poured, wait for the dough to be ready (about 15 min)

6.3 - Extrusion

1. Ensure the proper extruder is fitted on the locking ring
2. Turn the shutter lever to "O"
3. The spiral will process the dough. Once the pasta will reach an adequate pressure the extruding will begin.
4. Cut with a knife the dough that comes out of the extruder to the necessary length
5. When the basin is empty, shut off the machine.

6.4 - Using the dough cutter

1. Attach the pasta cutter accessory "1" (Fig. 6.4.1) to the front pins of the pasta machine.
2. Insert connector "2" (Fig. 6.4.1) into connector "6" (Fig. 3.1.1).
3. Start the machine in die mode.
4. Intervene on potentiometer "3" (Fig. 6.4.1) to adjust the speed of the pasta cutter to cut the pasta to the desired length.

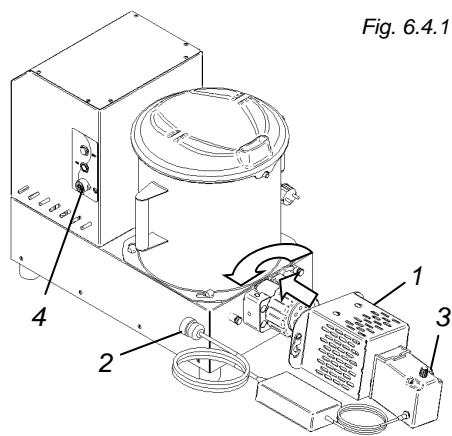

Any attempt of the user or unauthorized personnel to disassemble, modify or more generally tamper with any part of the machine will cause the Declaration of Conformity drawn up in accordance with **EEC Directives 2006/42** to lapse, it shall void the warranty and will relieved the Manufacturer from damages caused by such behaviour.

The Manufacturer shall be relieved of all liability in the following situations:

- incorrect installation;
- improper use of the equipment by inadequately trained personnel;
- use contrary to regulations in force in the country where the equipment is used;
- omitted or poor maintenance;
- use of non-original spares or not specific for the model;
- total or partial non-compliance with these instructions- with spare parts that are not original or are not specific for the model.

1.4 - Description of the machine

The machine in your possession is a simple, compact, highly efficient and powerful equipment.

- Since it must be used in food applications, the components were carefully chosen to provide maximum hygiene.
- Stainless steel tank.
- The tools are made of stainless steel to ensure durability and maximum hygiene.
- Bronze outlet and dies.
- Extruder outlet shutter system.
- Maximum mixing capacity 4.2 kg (3 kg flour 1.2 kg egg)
- Pre-arranged for dough-cutter installation.
- Ventilated single-phase motors offering the following advantages:
 - consistency, high performance and durability of the motor;
 - increases the real operation time due to fewer interruptions.

The version represented in this manual have been built in compliance with **EC Directive 2006/42** and further modifications.

In case of accident, no responsibility can be charged to the manufacturer if the machine has been modified, tampered with, if it has been used with the safety guards removed or for purposes not permitted by the manufacturer.

1.5 - Permitted use

The machine was designed and built for fresh pasta production.

It is to be used in professional environments; the machine operator has to be specialize din the field and have read and understood this manual. Do not use the machine unless safely fixed to a solid workbench.

1.6 - Improper use not permitted

The machine must be used exclusively for the purposes intended by the manufacturer; in particular:

- **do not** use the machine for food products other than those indicated by the manufacturer.
- **do not** use the machine unless it has been properly installed with all the

protections intact and properly assembled to avoid the risk of severe injury.

- **do not** access the electrical components without having previously disconnected the machine from the mains: **ones risks electrocution.**
- **Follow** the indicated flour / liquid quantities. Wrong quantities of ingredients can generate permanent damage to the machine.
- Do not wear clothing which do not follow the safety regulations. Check with your employer as regards the safety regulations and safety equipment to be provided with.
- **Do not** use the equipment if damaged.
- Before using the machine make sure that any dangerous condition has been appropriately cleared. In case of abnormal operation, stop the machine and warn the persons in charge with maintenance.
- **Do not** allow unauthorized persons to operate on the equipment. The emergency treatment in case of an accident caused by electrical shock implies to first remove the contact between the injured person from the conductor (since usually the person faints). This is dangerous operation. The victim in this case is a conductor: touch him/her could imply being electrocuted.
It should therefore first be remove contacts directly from the supply valve, otherwise move the victim using insulating materials (wood or PVC stick, cloth, leather, etc.). It is recommended to call for medical staff, the patient has to be transferred to a hospital.

5 - Starting-up and shutting-down

5.1 - Checking the electrical connections

Connect the plug to the mains and press the start button (1 Fig. 3.1.1). The machine gets enable in extruding mode; ensure the spiral direction of rotation is counter-clockwise.

Otherwise, disconnect the machine from the mains and contact your supplier.

Note: In the machines connected to a single phase line, manufactured for this specific power supply, the correct direction of rotation is determined directly by the manufacturer.

5.2 - Checking presence and effectiveness of safety devices and protections

1 - Interlocked cover

Ensure the machine stops when the upper cover is open.

When the cover is open the machine **must not** run.

5.3 - Checking the effectiveness of the emergency button (5 fig. 3.1.1)

When machine is connected to the mains and tools are in movement, press the shut down button (3 Fig. 3.1.1). The machine must shut down.

5.4 - Machine start up (1 or 3 fig. 3.1.1)

To start the machine, connect it to mains power, then press the start button (1) Fig. 3.1.1.

5.5 - Machine shut down (fig. 3.1.1)

To shut down the machine, push the shut down button, "3" Fig. 3.1.1.

maintenance. Prepare suitable lighting around the machine to ensure proper visibility to the machine operator.

- Remove the cellophane wrapping off the machine and other packaging present on the inside.

4.3.1 - Disposing the packaging

The components such as cardboard, nylon, wood products are comparable to municipal solid wastes. They can therefore be freely disposed off. The Nylon is a pollutant material that produces toxic fumes when burned. Do not burn it; dispose it off in accordance with the laws in force regarding the matter. If the machine is delivered in countries where special rules are implemented, the packaging must be disposed off according to such regulations.

4.3.2 - Handling the machine

WARNING!

Handle the machine with care and attention, avoid accidental falls that could damage it. To avoid muscle strain, when lifting the machine, use the force of the legs.

4.4 - Electrical connections

WARNING!

Ensure the mains match the voltage given on the equipment's ID plate. All interventions must be carried out exclusively by specialized and expressly authorized personnel. Carry out the electrical connection to properly earthed mains.

4.4.1 - Single phase machine 220 Volt-50 Hz

In this version the machine is supplied with a power cable having 3 x 1.5 mm cross section. The cable is connected to a three-poles single-phased plug.

Connect the cable to single phase 220 Volt-50 Hz mains; interpose a differential circuit breaker of 16 amps.

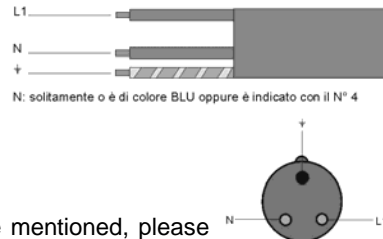

In installations with voltages other than those mentioned, please consult the manufacturer. Should it be necessary to lengthen the power cable, use a cable having the a cross section that matches the one installed by the manufacturer.

1.7 - Identification of the equipment

Providing an exact description of the "Version", the "Serial Number" and the "Year of manufacture" of the machine will allow rapid and effective answer from our customer service. It is recommended to indicate the machine version and serial number whenever you call for service.

Collect these data from the plate shown in Fig. 1.7.1. It is suggested to insert the machine identification data in the following table:

Machine version.....
Serial No.....
Year of manufacture.....
Type.....

A = machine version
 B = Voltage
 C = motor power
 D = motor frequency Hz
 E = Weight
 F = Amperage
 G = Year of manufacture
 H = Serial No.
 I = Manufacturer
 L = Barcode

Fig. 1.7.1

WARNING!

Do not alter the data on the identification plate under any any circumstances.

1.7.1 - Warning plates (fig. 1.7.2)

WARNING!

Do not intervene on electrical components when the machine is connected to the mains . **Ones risks electrocution. Follow the indications on the plates.**
Failure to comply to the recommendations could result in personal injury.
Make sure the plates are always in place and readable.
Otherwise apply or replace them.

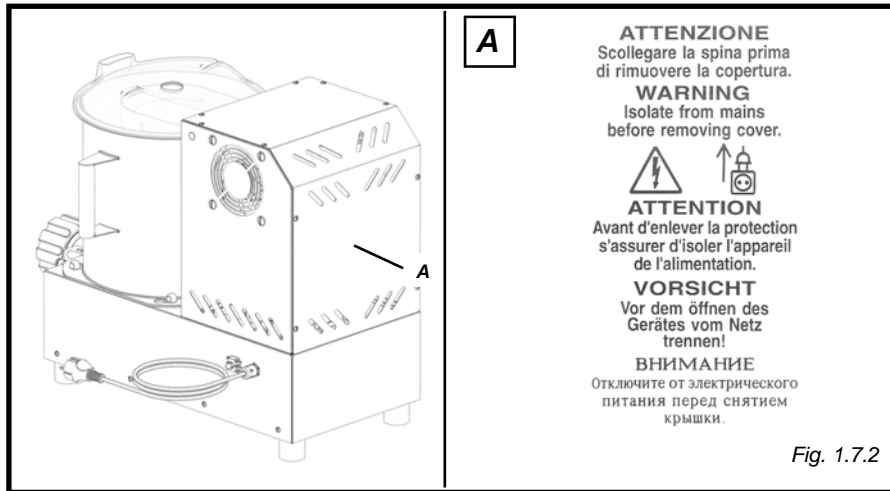

3 - Controls and indicator lights

3.1 - List of controls and indicator lights

1 - Start mixer button (1 fig. 3.1.1)

By pushing the button the machine starts in mixer mode

2 - Extrusion start button led

Lights up when the button is pressed. (2 fig. 3.1.1)

3 - Shut- down button

Push this button to shut down the machine.

4 - Connector for dough-cutter application

Required to apply the dough-cutter if envisaged.

CAUTION!

The machine is equipped with a forced ventilation system (fan) controlled by a bimetallic switch connected to the motor. When the motor reaches 60 °C, the fan starts autonomously and continues operating until the motor's temperature drops down to 40 °C.

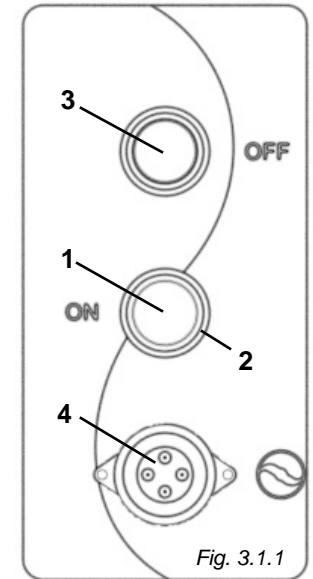

4 - Inspection, shipping, delivery and installation

4.1 Inspection

The equipment in your possession has been tested at our factory to verify that all moving parts work properly and it is properly adjusted.

4.2 - Shipping and handling the machine

All materials shipped have been thoroughly checked before delivery to the shipping company. Unless otherwise agreed upon with the customer, the machine is wrapped with nylon and fixed with steel straps on the bench, cover by a box which is also fixed with steel straps to the pallet. On receiving the machine, check the integrity of the packaging. In case of damage to the packaging, the carrier shall sign the notice of receipt for instance which should sound like this: "I tentatively accept..." and the reason.

ON opening the packaging, in case of badly damaged components of the machine, file a complaint to the shipping company within three days from the date indicated on the documents.

4.3 - Installation

WARNING!

The machine installation area has to be sturdy and the surface has to ensure a safe support. When positioning the machine keep extensive space around it. This allows greater manoeuvrability during operation and ensures access for

2.5 - Electrical diagrams
2.5.1 - 230V / 50 Hz 1 ph

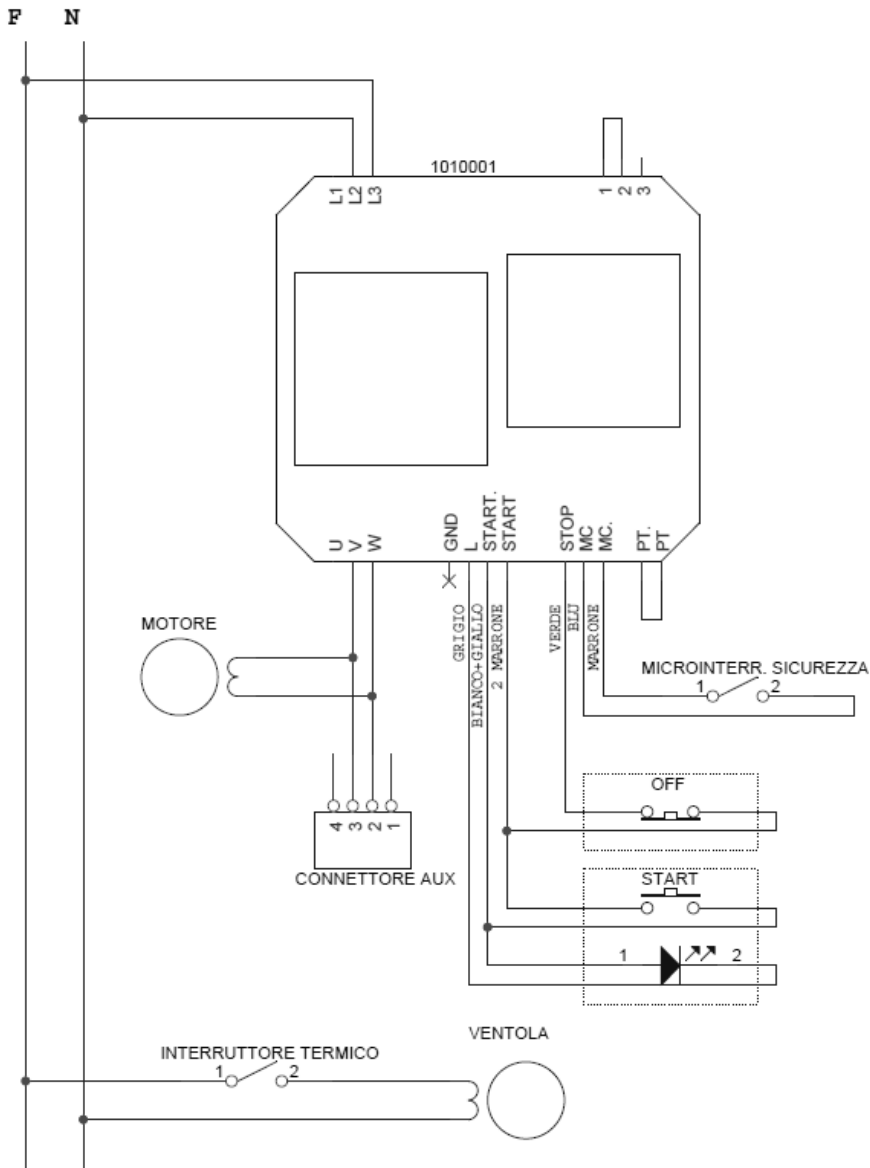

1.8 - Safety devices and protections

WARNING!

Before use ensure that all the safety devices are installed and working properly. Before each working shift ensure that all the safety devices are installed and that they are working properly. Otherwise contact the person in charge with maintenance activity.

1 - Cover sensor.

The machine cannot be turned on when the cover is removed.

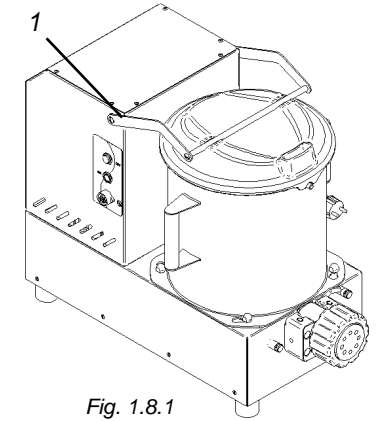

Fig. 1.8.1

WARNING!

Do not tamper with the safety devices.

1.9 - Operating station

The correct position that the operator must occupy to optimize the working with the machine is shown in fig. 1.9.1.

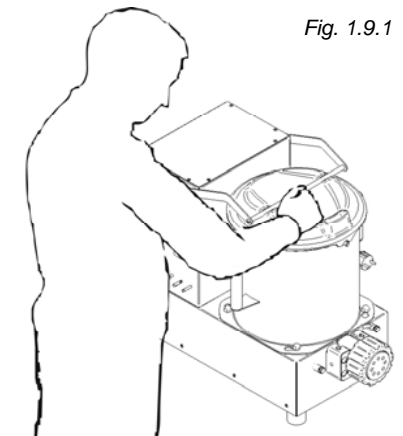

Fig. 1.9.1

2 - Technical features

2.1 - Main components

To facilitate the understanding of the manual, hereafter there are listed below and shown in fig. 2.1.1. the main parts of the machine.

1. Feet
2. Dough basin
3. Bronze dies
4. Safety sensor
5. Feeder funnel
6. Pasta shutter lever
7. Casing
8. Interlocked cover

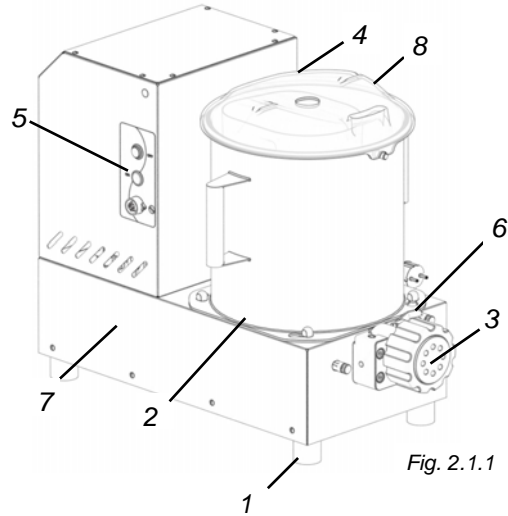

2.2 - Technical features

Motor	Supply	Hourly capacity	Extruders
watt/hp	V/Hz	kg/h.	ø mm
750/1	230/50	8,4	75

2.3 - Dimensions and weight of the machine

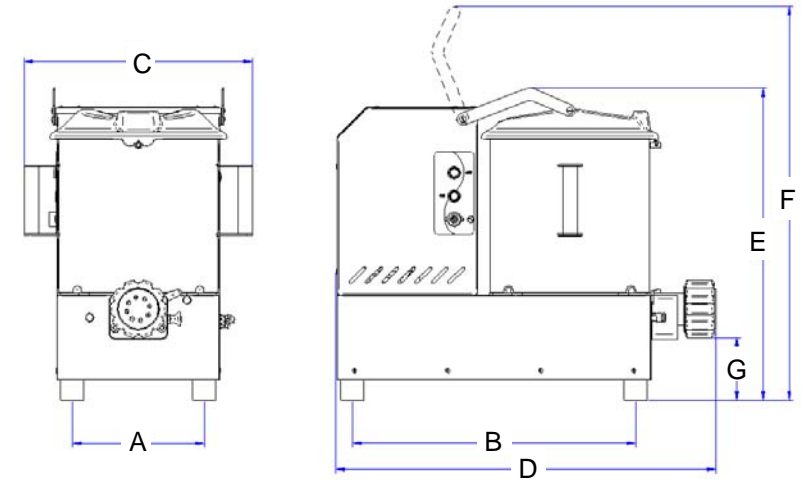

A	B	C	D	E	F	G	Net weight
mm	mm	mm	mm	mm	mm	mm	kg
227	487	393	653	535	680	107	67

2.4 - Noise level

The measured machine equivalent noise level does not exceed 70 dB.